

Agmate Eurocardan Driveline Table of Contents



Section A	Eurocardan Complete PTO Assemblies with Shielding by style and type
	A1 Smooth Bore yokes - Implement end
	A1 Shear Pin yokes - Implement end
	A2 Slip Clutch style - Implement end
	A3 QD Splined yokes - both Implement and Tractor ends
Section B	Eurocardan Complete PTO Assemblies with Shielding by application
	B1-B3 Rotary Cutters
	B4 Tillers
	B4 Post Hole Diggers
	B5 Flail Mowers
	B5 Disc Mowers
	B5 Hay Tedders
	B5 Fertilizer Spreaders
	B6 Sprayers
	B6 Hydraulic Pumps
	B7 Generators
Section C	Eurocardan Complete Constant Velocity (CV) PTO Assemblies with Shielding
Section D	Eurocardan Complete Constant Velocity (CV) PTO Assemblies with Shielding by application
	D1 Peanut Combines
	D1 Rotary Cutters
Section E	Eurocardan Parts - Standard Drivelines & York style
Section F	Eurocardan Parts - Replacement Shielding
Section G	Eurocardan Parts - Constant Velocity Drivelines, including Shielding
Section H	Problem Solving

Note: The following pages represent Agmate's current offering of stocked Eurocardan driveline assemblies and parts - which does not represent the complete Eurocardan product offering. Other sizes and styles of drivelines, as well as parts, may be available on either a special order or custom stocking program basis. If you have a requirement that you don't see listed, please don't hesitate to contact us.



WARNING - BE SURE TO USE PROPER LENGTH PTO!!!

It is not implied in our literature that when a size is listed to fit a specific application that the length is correct. Some manufacturers use different lengths; that length should be used.

The applications recommended are to be considered only as a guideline.

Always allow 1/3 of shaft tube to be in at all times.

ALWAYS KEEP SHIELDING IN WORKING ORDER AND IN PLACE



Terms and Conditions



Prices subject to change without prior notice - Please ask for quote.

Warehouse: FOB Selma, NC Best price is available with a \$1,000 minimum order. 10% surcharge added for orders under \$1,000. Exceptions: PTO parts

Half Container: FOB Selma, NC This price is available on 1/2 truck load orders. All items may be combined to meet the 20,000 lb. requirement. Standard lead time is 120 days; but shorter lead times are subject to product availability.

Full Container: FOB Port This price is available on all containers shipped directly from the supplier. Items may be combined to meet the 38,000 lb. container requirement. Lead time is minimum 120 days.

Terms: Net 10 days

Warranty: Agmate sells only the highest quality products available in today's market. All Agmate products are guaranteed to be free of defects in workmanship and materials. All Agmate products are guaranteed to fit the machine for which they are intended. Agmate will not honor any claim for warranty on any part that has been altered in any way by anyone else but Agmate. All claims for warranty must be made in writing to Dick Jones & Associates, Inc., the Agmate representatives.

Please direct all claims to:
Dick Jones & Associates, Inc.
PO Box 3835
Cleveland, TN 37320-3835

You will then be advised as to the disposition of the parts. Do not ship any parts back to Agmate or Dick Jones & Associates, Inc. unless requested to do so. Settlements of warranty claims will be in the form of a credit memo to be used towards future purchases at Agmate or free replacement of the part will be shipped immediately if part is in stock. If after receiving written notice, Agmate determines the parts should be returned for inspection, you will be notified to return some or all of the parts. The parts should be returned freight prepaid unless otherwise approved. If after inspection it is determined that the parts are defective, credit will be issued for parts and reimbursement for your freight charges. Agmate does not authorize any repairs in the field or labor charges for replacements. Agmate reserves the right to alter this warranty and make product changes without notice.

Items: Cross reference #'s do not imply original OEM parts. Weights are estimated.

PTOs: BE SURE TO USE THE PROPER LENGTH PTO! It is not implied in this literature that when a certain size is listed that the length is correct. Some manufacturers use different lengths; that length should be used. The applications recommended are to be considered only as a guideline. Always allow 1/3 of shaft tube to be in at all times. Be sure to keep shielding in place and use proper parts to fit assembly designed for. Replace all worn or stretched parts. Make sure shielding is always in place.



EUROCARDAN PTO ASSEMBLIES AND ACCESSORIES



ENDING CODES IN PART NUMBERS AS FOLLOWS:

- SP SHEAR PIN YOKE held on by snap ring
- SPSS SHEAR PIN/SET SCREW held on by set screw in groove of shaft
- SMKEY SMOOTH BORE / KEYWAY/SET SCREW
- SPF LC SHEAR PIN BOLT FLANGE
- SPL SPLINE ENDS

- FDO 2 DISC SLIP CLUTCH (6200 IN LBS)
- FD1 2 DISC SLIP CLUTCH (7960 IN LBS)
- FD2 2 DISC SLIP CLUTCH (10620 IN LBS)
- FD3 4 DISC SLIP CLUTCH (13270 IN LBS)
- FD4 4 DISC SLIP CLUTCH (19470 IN LBS)

- CV 80 DEGREE CONSTANT VELOCITY U-JOINTS

- LN2 2 PAWL TYPE Torque limiter clutch (7780 in LBS)
- LN3 3 PAWL TYPE Torque limiter clutch (10000 in LBS)

- RL1 FREE WHEEL overrun clutch (14160 in LBS)
- RL2 FREE WHEEL overrun clutch (21240 in LBS)

- F SHIELD COVERS COMPLETE YOKE
- A SHIELD STD COVERS X EA END

- /QR ADDED ON P/N QUICK RELEASE (collar type yoke one or both ends)
- /QD ADDED ON P/N PUSH PIN YOKE RELEASE (Twist Lock/Push Pin collar type yoke on one or both ends)
- /MC ADDED ON P/N METAL COLLAR YOKE RELEASE (Metal collar/Pull type yoke on one or both ends)

- /1021 ADDED ON P/N 1 3/8-21 SPL one or both ends
- /1020 ADDED ON P/N 1 3/4-20 SPL one or both ends
- /IB ADDED ON P/N INTERFERING BOLT TYPE YOKE
- /NIB ADDED ON P/N NON INTERFERING BOLT TYPE YOKE

EUROCARDAN INTERCHANGEABILITY CHART/HP RATINGS				
ASAE	METRIC	USA	HP@540RPM	HP@1000RPM
1	1	6N	16 hp	25 hp
2	2	12N	21 hp	31 hp
3	3		30 hp	47 hp
3	4	14N	35 hp	55 hp
4	5		47 hp	74 hp
5	6	35N	64 hp	100 hp
5	7	44R	75 hp	118 hp
6	8	55N	95 hp	150 hp
	9		120 hp	190 hp
	10		145 hp	230 hp

25.4mm = 1 inch
FOB WAREHOUSE, SELMA NC 27576
I.E. = Implement End
T.E. = Tractor End



WARNING - BE SURE TO USE PROPER LENGTH PTO!!!
 It is not implied in our literature that when a size is listed to fit a specific application that the length is correct. Some manufacturers use different lengths; that length should be used.
 The applications recommended are to be considered only as a guideline.
 Always allow 1/3 of shaft tube to be in at all times.



ALWAYS KEEP SHIELDING IN WORKING ORDER AND IN PLACE

Complete Eurocardan PTO Assemblies With Shielding



Smooth Bore & Shear Pin Implement End Yoke



Agmate Part Number	Assembly Description	Series Size	Length Overall	Description	I.E. = Implement End	T.E. = Tractor End
51440	TX15053A-SMKEY (3/4")	1	28"	3/4" smooth bore w/keyway / set screw / 1 3/8-6 T.E.		
51441	TX1530A-SMKEY (15/16")	1	28"	15/16" smooth bore w/keyway / set screw / 1 3/8-6 T.E.		
51442	TX1530A-SMKEY (5/8")	1	28"	5/8" smooth bore w/keyway / set screw / 1 3/8-6 T.E.		
36718	TX11110F-SPSS	1	50.5"	1 1/4" smooth yoke w/set screw shaft lock / 3/8" shear pin / 1 3/8-6 T.E.		
59328	RS1-530-SP	1	27.68"	1-3/16" smooth yoke w/ 3/8 shear pin hole / 1-3/8-6 T.E.		
59332	TX1610A-SMKEY	1	31"	1" smooth bore / 1-3/8 T.E.		
59333	TX1610A-SMKEY	1	31"	1" smooth bore / 1 3/8-21 T.E.		
54717	TX4760F-SMKEY	4	38"	1 1/8" smooth bore w/keyway / set screws / 1 3/8-6 T.E.		
35736	TX4610F-SP	4	31.9"	1 3/8" smooth yoke w/ 1/2" shear pin hole / 1 3/8-6 T.E.		
35732	TX4710F-SP	4	35.8"	1 3/8" smooth yoke w/ 1/2" shear pin hole / 1 3/8-6 T.E.		
35734	TX4760F-SP	4	37.8"	1 3/8" smooth yoke w/ 1/2" shear pin hole / 1 3/8-6 T.E.		
35735	TX4880F-SP	4	42.5"	1 3/8" smooth yoke w/ 1/2" shear pin hole / 1 3/8-6 T.E.		
36064	TX41110F-SP	4	51.5"	1 3/8" smooth yoke w/ 1/2" shear pin hole / 1 3/8-6 T.E.		
35733	TX41110F-SPSS	4	51.5"	1 1/4" smooth yoke w/set screws shaft lock / 3/8" shear pin 1 3/8-6 T.E.		
33237	AX41110F-SMKEY	4	51.6"	1" smooth bore / keyway / set screws / 1 3/8-6 T.E.		
33982	AX41110F-SMKEY-1021	4	51.6"	1" smooth bore / keyway / set screws / 1 3/8-21 T.E.		
31361	TX5910F-SP	5	44"	1 3/8" smooth yoke w/ 1/2" shear pin hole / 1 3/8-6 T.E.		
45904	TX51010F-SMKEY	5	48"	1 1/2" smooth bore / keyway / set screw / 1 3/8-6 T.E.		
36283	AX51010F-SMKEY/1021	5	48"	1 1/2" smooth bore / keyway / set screw / 1 3/8-21 T.E.		
39990	TX51210F-SP	5	55.9"	1 3/8" smooth yoke w/ 1/2" shear pin hole / 1 3/8-6 T.E.		



WARNING - BE SURE TO USE PROPER LENGTH PTO!!!

It is not implied in our literature that when a size is listed to fit a specific application that the length is correct. Some manufacturers use different lengths; that length should be used.

The applications recommended are to be considered only as a guideline.

Always allow 1/3 of shaft tube to be in at all times.

ALWAYS KEEP SHIELDING IN WORKING ORDER AND IN PLACE



Complete Eurocardan PTO Assemblies with Shielding



Slip Clutch Implement End Yoke

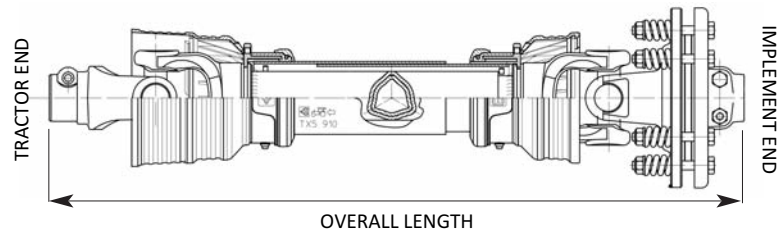

Agmate Part Number	Assembly Description	Series Size	Length Overall	I.E. = Implement End T.E. = Tractor End	
34241	AX4480FD1A-SC/QR	4	28.7"	FD1 slip clutch 1 3/8-6 I.E. / 1 3/8-6 QR yoke T.E.	
40944	AX4500FDO-SC	4	29.5"	FDO slip clutch 1 3/8-6 I.E. / 1 3/8-6 QD yoke T.E.	
45902	TX4710FD1A-SC	4	37.7"	FD1 slip clutch 1 3/8-6 I.E. / 1 3/8-6 QD yoke T.E.	
45906	TX4880A-FD1	4	44.3"	FD1 slip clutch 1 3/8-6 I.E. / 1 3/8-6 QD yoke T.E.	
45905	TX5710FD2A-HDSC	5	38"	FD2 slip clutch 1 3/8-6 I.E. / 1 3/8-6 QD yoke T.E.	
42969	TX5910FD2	5	46"	FD2 slip clutch 1 3/8-6 I.E. / 1 3/8-6 QD yoke T.E.	
51986	AX6910FD4	6	48"	FD4 slip clutch 1 3/8-6 I.E. / 1 3/8-6 QD yoke T.E.	
51445	AX6710FD2A-SC	6	38.6"	FD2 slip clutch 1 3/8-6 interfering bolt I.E. / 1 3/8-6 MC yoke T.E.	
34243	AX6710FD4A-HDSC/MC	6	39.5"	FD4 slip clutch 1 3/8-6 I.E. / 1 3/8-6 MC yoke T.E.	
81331	AX6860FD2	6	45"	FD2 slip clutch 1 3/4-20 IB / 1 3/8-6 MC T.E.	
32185	AX61110FD2A-HDSC	6	54.5"	FD2 slip clutch 1 3/8-6 I.E. / 1 3/8-6 QD yoke T.E.	
34192	AX61210FD2A-HDSC	6	58"	FD2 slip clutch 1 3/8-6 I.E. / 1 3/8-6 QD yoke T.E.	
34240	AX61240FD4/MC	6	61"	FD4 slip clutch 1 3/4-20 I.E. / 1 3/8-6 MC yoke T.E.	
38750	AX61240FD4/MC/1020	6	61"	FD4 slip clutch 1 3/4-20 I.E. / 1 3/4-20 QR yoke T.E.	
69075	AX61553FD2	6	61"	FD2 slip clutch 1 3/4-20 IB / 1 3/4-20 IB T.E.	
34193	AX61440FD2A-HDSC	6	67.3"	FD2 slip clutch 1 3/8-6 I.E. / 1 3/8-6 QD yoke T.E.	
54290	AX81240FD4/1020	8	61"	FD4 slip clutch 1 3/4-20 I.E. / 1 3/4-20 QD T.E.	
47286	AX81210FD4	8	60"	FD4 slip clutch 1 3/4-6 I.E. / 1 3/4-20 QD T.E.	
75029	YE01123-FD4	10	61"	FD4 slip clutch 1 3/4-20 / 1 3/4-20 MC T.E. York tubing	



WARNING - BE SURE TO USE PROPER LENGTH PTO!!!

It is not implied in our literature that when a size is listed to fit a specific application that the length is correct. Some manufacturers use different lengths; that length should be used.

The applications recommended are to be considered only as a guideline.

Always allow 1/3 of shaft tube to be in at all times.

ALWAYS KEEP SHIELDING IN WORKING ORDER AND IN PLACE



Complete Eurocardan PTO Assemblies with Shielding



Splined Implement End Yoke

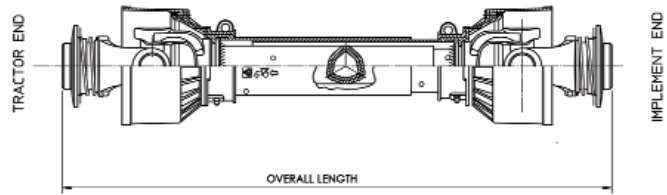

Agmate Part Number	Assembly Description	Series Size	Length Overall	I.E. = Implement End T.E. = Tractor End
31963	RX1510A-SPL	RX1	27.4"	1 3/8-6 QD spline yoke both ends
33028	AX1610A-SPL	1	31"	1 3/8-6 QD spline yoke both ends
53726	TX1660F-SPL/MC	1	33.5"	1 3/8 QR metal collar on both ends
41527	AX4580A-SPL	4	31.3"	1 3/8-6 QD spline yoke both ends
53920	TX4760F-SPL	4	38"	1 3/8-6 spline w/5/16" pin hole I.E. / 1 3/8-6 spline T.E.
54980	TX4750/1021	4	38"	1 3/8-21 SP IB both ends
54718	TX4810F-SPL	4	40"	1 3/8-6 spline yoke both ends
33236	AX41110F-SPL	4	52.2"	1 3/8-6 spline yoke both ends
33029	AX5610A-SPL	5	32.7"	1 3/8-6 spline yoke both ends
39717	TX5910F-SPL	5	44.6"	1 3/8-6 spline yoke both ends
33235	AX61110F-SPL	6	53"	1 3/8-6 spline yoke both ends
34195	AX8750F-SPL/MC	8	39.6"	1 3/8-6 spline metal collar yoke both ends
42995	BX8980A-SPL 1021	8BX	48.5"	1 3/8-21 spline I.E. / 1 3/8-6 spline T.E.; splined tubing
80882	YE101280-SPL	10	61"	1 3/4-20 spline MC both ends; york tubing



WARNING - BE SURE TO USE PROPER LENGTH PTO!!!

It is not implied in our literature that when a size is listed to fit a specific application that the length is correct. Some manufacturers use different lengths; that length should be used.

The applications recommended are to be considered only as a guideline.

Always allow 1/3 of shaft tube to be in at all times.

ALWAYS KEEP SHIELDING IN WORKING ORDER AND IN PLACE



Complete Eurocardan PTO Assemblies with Shielding



4', 5', 6', 7' Rotary Cutters With Shielding

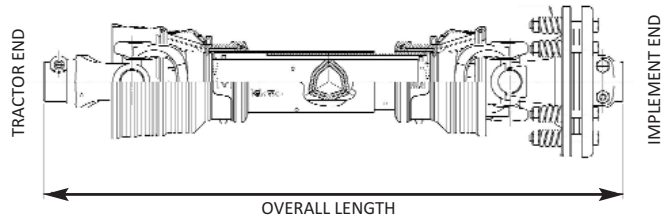

Agmate Part Number	Assembly Description	Series Size	Length Overall	Used On	I.E. = Implement End T.E. = Tractor End
54718	TX4810F-SPL	4	40"	Finishing Mower	1 3/8-6 spline both ends
35736	TX4610F-SP	4	31.9"	4' Lift Cutter	1/2" shear pin-1 3/8" smooth yoke / 1 3/8-6 SPL QD
35732	TX4710F-SP	4	35.8"	5' Lift Cutter	1/2" shear pin-1 3/8" smooth yoke / 1 3/8-6 SPL QD
45902	TX4710A-FD1	4	37.7"	5' Lift Cutter	FD1 slip clutch-1 3/8-6 SPL / 1 3/8-6 SPL QD
35734	TX4760F-SP	4	37.8"	5' Lift Cutter	1/2" shear pin-1 3/8" smooth yoke / 1 3/8-6 SPL QD
35735	TX4880F-SP	4	42.5"	6' Lift Cutter	1/2" shear pin-1 3/8" smooth yoke / 1 3/8-6 SPL QD
35836	TX4910A-SPF	4	44"	6' Lift Cutter	Shear pin flange 1 3/8-6 SPL / 1 3/8-6 SPL QD
45906	TX4880A-FD1	4	44.3"	6' Lift Cutter	FD1 slip clutch-1 3/8-6 SPL / 1 3/8-6 SPL QD
36064	TX41110F-SP	4	51.5"	5' Pull Cutter	1/2" shear pin-1 3/8" smooth yoke / 1 3/8-6 SPL QD
45905	TX5710A-FD2	5	38"	5' HD Lift Cutter	FD2 slip clutch-1 3/8-6 SPL / 1 3/8-6 SPL QD
31361	TX5910F-SP	5	44"	6' Lift Cutter	1/2" shear pin-1 3/8" smooth yoke / 1 3/8-6 SPL QD
42969	TX5910A-FD2	5	46"	6' Lift Cutter	FD2 slip clutch-1 3/8-6 SPL / 1 3/8-6 SPL QD
39717	TX5910F-SPL	5	46"	6' Lift Cutter	1 3/8"-6 spline both ends
81331	AX65000-0021	6	45"	6' Lift Cutter	FD2 Slip clutch-1 3/4-20 SPL IB / 1 3/8-6 SPL MC
39990	TX51210F-SP	5	55.9"	6' Pull Cutter	1/2" shear pin-1 3/8" smooth yoke / 1 3/8-6 SPL QD
51986	AX6910F-FD4	6	48"	6' HD Lift Cutter	FD4 slip clutch - 1 3/8-6 SPL / 1 3/8-6 SPL QD
32185	AX61110A-FD2	6	54.5"	7' Lift Cutter	FD2 slip clutch-1 3/8-6 SPL / 1 3/8-6 SPL QD
33235	AX61110F-SPL	6	56"	7' Lift Cutter	1 3/8-6 spline both ends
34192	AX61210A-FD2	6	58.2"	6' Pull Cutter	FD2 slip clutch-1 3/8-6 SPL / 1 3/8-6 SPL QD
34193	AX61440A-FD2	6	67.3"	7' Pull Cutter	FD2 slip clutch-1 3/8-6 SPL / 1 3/8-6 SPL QD



WARNING - BE SURE TO USE PROPER LENGTH PTO!!!

It is not implied in our literature that when a size is listed to fit a specific application that the length is correct. Some manufacturers use different lengths; that length should be used.

The applications recommended are to be considered only as a guideline.

Always allow 1/3 of shaft tube to be in at all times.

ALWAYS KEEP SHIELDING IN WORKING ORDER AND IN PLACE



Rotary Cutter Eurocardan PTO Assemblies with Shielding

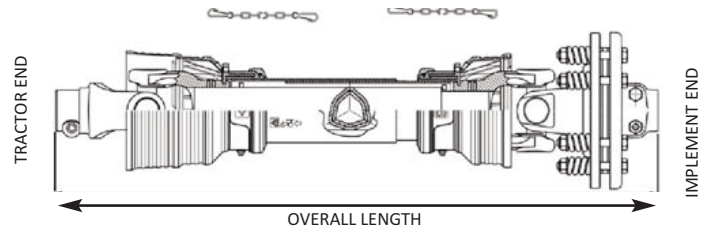

8' & 10' Rigid Deck Rotary Cutters

Agmate Part Number	Assembly Description	Series Size	Length Overall	Used On	Description
45905	TX5710A-FD2	5	38"	8' Lift Type Main Drive	FD2 Slip Clutch - 1 3/8-6 SPL
42969	TX5910A-FD2	5	46"	10' Lift Type Main Drive	FD2 Slip Clutch - 1 3/8-6 SPL
34193	AX61440A-FD2	6	67.3"	10' Pull Type Main Drive	FD2 Slip Clutch - 1 3/8-6 SPL
34137	ME61410CV-FD2	CV6	70"	10' Pull Type Constant Velocity	FD2 Slip Clutch - 1 3/8-6 SPL

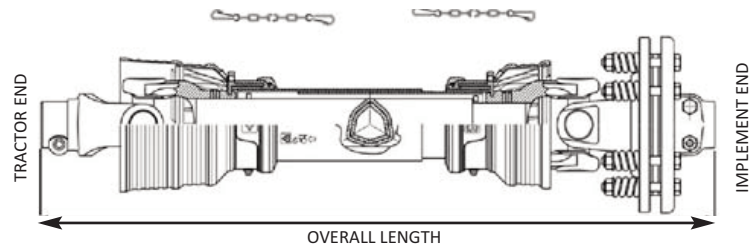

15' Flex Wing Cutters with Shielding

Agmate Part Number	Assembly Description	Series Size	Length Overall	Used On	Description
34192	AX61210A-FD2	6	58.2"	15' Wing	FD2 slip clutch 1 3/8-6 I.E./1 3/8-6 QD T.E.
69075	AX61280A-FD2	6	61.3"	15' Wing	FD2 slip clutch 1 3/4-20 IB I.E. / 1 3/4-20 IB T.E.
34240	AX61240A-FD4/1020/MC	6	60.5"	15' Wing	FD4 slip clutch 1 3/4-20 I.E./1 3/8-6 MC T.E.
38750	AX61240A-FD4/1020/MC	6	60.93"	15' Wing	FD4 slip clutch 1 3/4-20 I.E./1 3/4-20 MC T.E.
54290	AX81240A-FD4/1020/MC	8	61.2"	15' Wing	FD4 slip clutch 1 3/4-20 I.E./1 3/4-20 MC T.E.



WARNING - BE SURE TO USE PROPER LENGTH PTO!!!

It is not implied in our literature that when a size is listed to fit a specific application that the length is correct. Some manufacturers use different lengths; that length should be used.

The applications recommended are to be considered only as a guideline.

Always allow 1/3 of shaft tube to be in at all times.

ALWAYS KEEP SHIELDING IN WORKING ORDER AND IN PLACE



Rotary Cutter Eurocardan PTO Assemblies with Shielding



Flexible Cross Shafts 3 Gear Box Connection 8' & 10'

Agmate Part Number	Assembly Description	Series Size	Length Overall	Used On	Description
33231	GE5325-SPL Single Pad	5	12.8"	8' Flex Coupler	w/u-joint 1 3/8-6 both ends / yoke no pin hole
36949	GE5324-SPL/NIB Single Pad	5	12.75"	8' Flex Coupler	w/u-joint 1 3/8-6 both ends / yoke interfering bolt
36950	GE5425-SPL/NIB Double Pad	5	16.73"	10' Flex Coupler	w/u-joint 1 3/8-6 both ends / yoke interfering bolt
34249	GE5445-SPL/13/4-20 IB Double Pad	5	17.5"	10' Flex Coupler	w/u-joint 1 3/8-6 pad end / 1 3/4-20 yoke interfering bolt
34138	GE5470-SPL Double Pad	5	18.5"	10' Flex Coupler	w/u-joint 1 3/8-6 both ends / yoke no pin hole
56204	GE8425-SPL/1 3/4-20 IB Double Pad	8	16.73"	10' HD Flex Coupler	1 3/8-6 pad end / 1 3/4-20 yoke interfering bolt

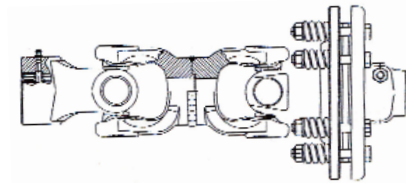

Gear Box Connector Shafts Flex Wing Mowers

Agmate Part Number	Assembly Description	Series Size	Length Overall	Used On	Description
45912	BX6214-FD2 Slip Clutch No Pad	6	19.01"	Gear Box Connector	1 3/8-6 QD yoke / FD2 1 3/8-6 slip clutch w/spline slip shaft
69080	DG6174-FD2	6	17"	15' Flex Wing Cutter	1 3/4-20 QD yoke / FD2 1 3/4-20

Slip Clutch Attachments

Agmate Part Number	Description	In./LB Torque
31951	FDS1 spline shaft and hub; use w/up to series 6	1 3/8-6 splines 7970
32323	FDS1 smooth shaft and hub; use w/up to series 6 (for converting shear pin to slip clutch)	1 3/8-6 smooth 7970
36065	FDS4 spline shaft and hub; use w/up to series 8	1 3/8-6 splines 19470



WARNING - BE SURE TO USE PROPER LENGTH PTO!!!

It is not implied in our literature that when a size is listed to fit a specific application that the length is correct. Some manufacturers use different lengths; that length should be used.

The applications recommended are to be considered only as a guideline.

Always allow 1/3 of shaft tube to be in at all times.

ALWAYS KEEP SHIELDING IN WORKING ORDER AND IN PLACE



Complete Eurocardan PTO Assemblies with Shielding



Post Hole Digger PTO with Shielding

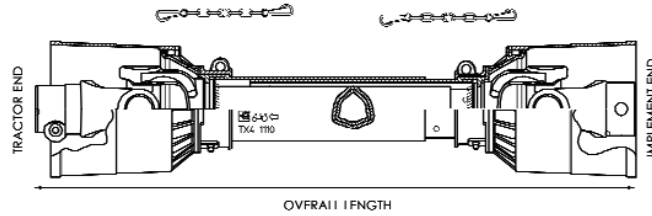

Agmate Part Number	Assembly Description	Series Size	Length Overall	Used On	Description
36718	TX11110F-SPSS	1	50.5"	1 1/4" smooth yoke w/set screw shaft lock	3/8" shear pin
35733	TX41110F-SPSS	4	51.5"	1 1/4" smooth yoke w/set screw shaft lock	3/8" shear pin

Tiller PTO with Shielding

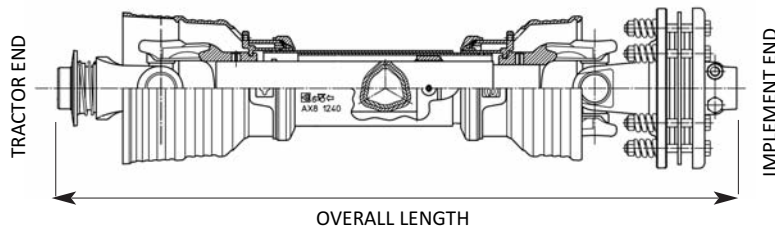

Agmate Part Number	Assembly Description	Series Size	Length Overall	Used On	Description
34241	AX4480A-FD1/QR	4	28.7"	Small tillers	FD1 slip clutch-1 3/8-6 spline
40944	AX4500A-FDO	4	29.45"	Small tillers	FDO slip clutch-1 3/8-6 spline
41527	TX4580A-SPL	4	31.34"	Small tillers	1 3/8-6 spline both ends
45902	TX4710A-FD1	4	37.7"	Light duty tillers	FD1 slip clutch-1 3/8-6 spline
45905	TX5710A-FD2	5	38"	Medium duty tillers	FD2 slip clutch-1 3/8-6 spline
39717	TX5910F-SPL	5	46"	Medium duty tillers	1 3/8-6 spline both ends
42969	TX5910A-FD2	5	46"	Medium duty tillers	FD2 slip clutch-1 3/8-6 spline
34243	AX6710A-FD4/MC	6	39.5"	Heavy duty tillers	FD4 slip clutch-1 3/8-6 spline

Miscellaneous PTO with Shear Pin Flange & Special Flange IE Yokes

Agmate Part Number	Assembly Description	Series Size	Length Overall	Description
39020	AX1460A-SPF	1	25.5"	Shear pin flange 1" smooth T.E. 7/8 smooth NIB I.E.
35836	TX4910A-SPF	4	44"	6' Lift Cutter / Shear pin flange 1 3/8-6 I.E. / 1 3/8-6 T.E.
46269	AX8910A-FLANGE/MC	8	46"	Ditcher special flange plate on I.E. 1 3/8-6 MC T.E.



WARNING - BE SURE TO USE PROPER LENGTH PTO!!!

It is not implied in our literature that when a size is listed to fit a specific application that the length is correct. Some manufacturers use different lengths; that length should be used.

The applications recommended are to be considered only as a guideline.

Always allow 1/3 of shaft tube to be in at all times.

ALWAYS KEEP SHIELDING IN WORKING ORDER AND IN PLACE



Complete Eurocardan PTO Assemblies with Shielding



Flail Mower PTO Assemblies with Shielding (Fits Mott)

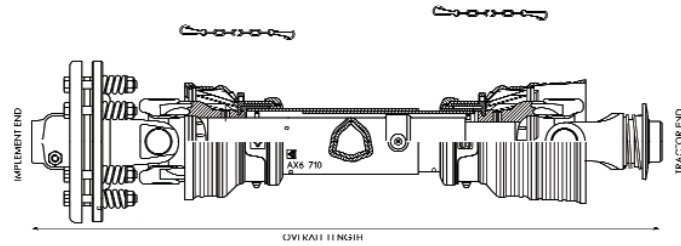

Agmate Part Number	Assembly Description	Series Size	Length Overall	Used On	Description
51445	AX6710A-FD2 / MC / IB	6	38.6"	FD2 slip clutch	1 3/8-6 interfering bolt I.E. 1 3/8-6 spline MC T.E.

Disc Mower PTO with Shielding

Agmate Part Number	Assembly Description	Series Size	Length Overall	In./LB Torque	Used On	Description
33029	AX5610A-SPL	5	32.7"			1 3/8-6 spline both ends
38202	AX4730A-RL1	4	38.2"	14160	RL1 over running clutch	1 3/8-6 spline
71428	AX5700A-RL2	5	38.1"	21420	RL2 over running clutch	1 3/8-6 spline

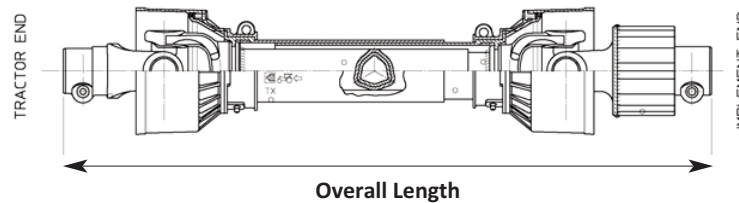

Hay Tedder PTO with Shielding

Agmate Part Number	Assembly Description	Series Size	Length Overall	In./LB Torque	Used On	Description
45903	TX21200A-LN2	2	57.3"	7780	LN2 pawl torque limiter clutch	1 3/8-6 spline
54979	TX41200A-LN3	4	58.38"	10000	LN3 pawl torque limiter clutch	1 3/8-6 spline

Fertilizer Spreader PTO with Shielding

Agmate Part Number	Assembly Description	Series Size	Length Overall	Used On	Description
31963	RX1510A-SPL	RX1	27.4"	Lift type spreader	1 3/8-6 spline both ends (lemon tube)



WARNING - BE SURE TO USE PROPER LENGTH PTO!!!

It is not implied in our literature that when a size is listed to fit a specific application that the length is correct. Some manufacturers use different lengths; that length should be used.

The applications recommended are to be considered only as a guideline.

Always allow 1/3 of shaft tube to be in at all times.

ALWAYS KEEP SHIELDING IN WORKING ORDER AND IN PLACE



Complete Eurocardan PTO Assemblies with Shielding



Sprayer Pump PTO with Shielding

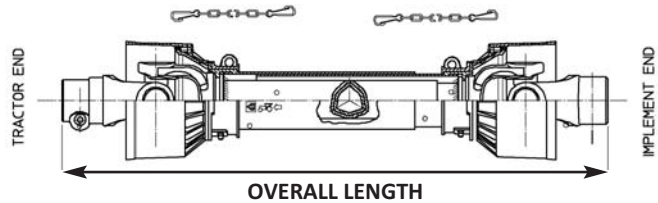

Agmate Part Number	Assembly Description	Series Size	Length Overall	Description
51440	TX1530F-SMKEY	1	28"	3/4" smooth bore w/keyway/set screw/ 1 3/8-6 T.E.
51441	TX1530F-SMKEY	1	28"	15/16" smooth bore w/keyway/set screw/ 1 3/8-6 T.E.
51442	TX1530F-SMKEY	1	28"	5/8" smooth bore w/keyway/set screw/ 1 3/8-6 T.E.
59332	TX1610-SMKEY	1	31"	1" smooth bore w/keyway/set screw/ 1 3/8-6 T.E.
59333	TX1610-SMKEY/1021	1	31"	1" smooth bore w/keyway/set screw/ 1 3/8-21 T.E.
33028	AX1610A-SPL	1	31"	1 3/8-6 spline both ends
53726	TX1680F-SPL / MC	1	33.5"	1 3/8-6 MC metal collar on both ends - Poultry House
33236	AX41110F-SPL	4	52.2"	1 3/8-6 spline both ends
33237	AX41110F-SMKEY	4	51.6"	1" smooth bore/keyway/set screws/ 1 3/8-6 T.E.
33982	AX41110F-SMKEY/1021	4	51.6"	1" smooth bore /keyway/set screws/ 1 3/8-21 T.E.
33029	AX5610A-SPL	5	32.7"	1 3/8-6 spline on both ends

Hydraulic Pump PTO with Shielding

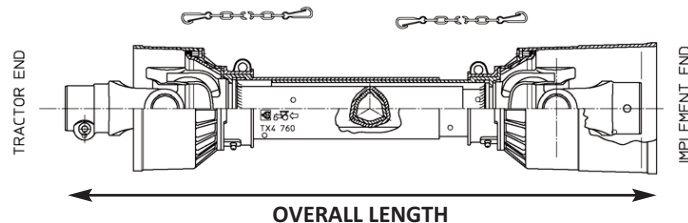

Agmate Part Number	Assembly Description	Series Size	Length Overall	Description
53920	TX4760F-SPL	4	38"	1 3/8-6 spline yoke w/8mm (5/16") pin hole I.E. 1 3/8-6 QD T.E.
54980	TX4750/1021	4	38"	1 3/8-21 SPL IB both ends



WARNING - BE SURE TO USE PROPER LENGTH PTO!!!

It is not implied in our literature that when a size is listed to fit a specific application that the length is correct. Some manufacturers use different lengths; that length should be used.

The applications recommended are to be considered only as a guideline.

Always allow 1/3 of shaft tube to be in at all times.

ALWAYS KEEP SHIELDING IN WORKING ORDER AND IN PLACE



Complete Eurocardan PTO Assemblies with Shielding



Over Running Attachments
for controlling inertia with non-live PTO



Agmate Part Number	Description	Used On	In./LB Torque
71429	RLS1-SPLQD Pin	1 3/8 T.E / 1 3/8 I.E. quick attach pin	14160
32439	RLS1-SPLQD Pin	1 1/8 T.E / 1 3/8 I.E. quick attach pin	14160

PTO Driven
Generator Drive Lines
with Shielding

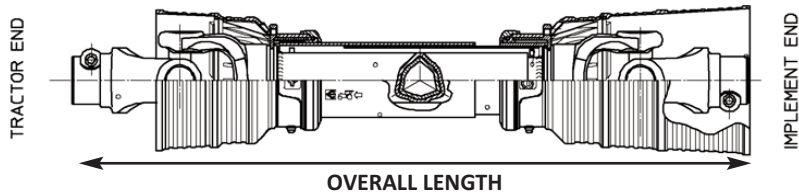

Agmate Part Number	Assembly Description	Series Size	Length Overall	Description
53726	TX1680F MC/SPL	1	33.5"	1 3/8 QR metal collar on both ends
54717	TX4760F-SMKEY	4	38"	1 1/8 smooth bore w/keyway/set screw/1 3/8-6 T.E.
41527	TX45804-SPL	4	31.3"	1 3/8-6 QD spline yoke both ends
54718	TX4810F-SPL	4	40"	1 3/8-6 spline yoke both ends
33236	AX41110F-SPL	4	52.2"	1 3/8-6 spline yoke both ends
39717	TX5910F-SPL	5	46"	1 3/8-6 spline both ends
33235	AX61110F-SPL	6	56"	1 3/8-6 spline both ends
34195	AX8750F-SPL/MC	8	39.6"	1 3/8-6 spline metal collar both ends
42995	BX8980A-SPL/1021	8 BX	60"	1 3/8-21 spline I.E. / 1 3/8-6 spline T.E. (with spline shaft)



WARNING - BE SURE TO USE PROPER LENGTH PTO!!!

It is not implied in our literature that when a size is listed to fit a specific application that the length is correct. Some manufacturers use different lengths; that length should be used.

The applications recommended are to be considered only as a guideline.

Always allow 1/3 of shaft tube to be in at all times.

ALWAYS KEEP SHIELDING IN WORKING ORDER AND IN PLACE



Complete Eurocardan Constant Velocity Drivelines with Shielding

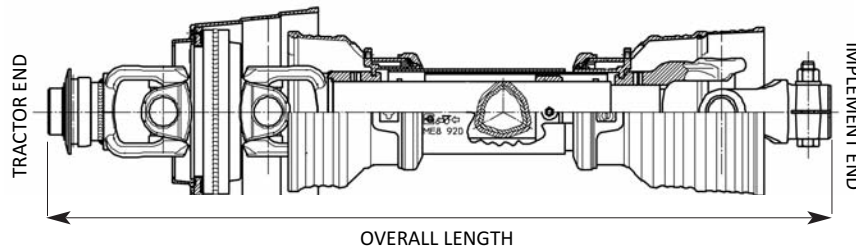

Agmate Part Number	Series	Type	Overall Length Collapsed	Tractor End	Implement End
39019	CV4	ME4820CV-SPL/MC	44.6"	80 deg CV w/ 1-3/8 6 spline MPC	1-3/8 6 spline MPC Yoke
55970	CV6	ME61410CV-SPL	69.1"	80 deg CV w/ 1-3/8 6 spline MPC	1-3/4 20 spline interfering bolt
34137	CV6	ME61410CV-FD2	70.2"	80 deg CV w/ 1-3/8 6 spline MPC	1-3/8 6 spline 2 disc friction clutch
55903	CV8	ME8660CV-SPL	41"	80 deg CV w/ 1-3/8 6 spline MPC	1-3/8 6 spline interfering bolt
54289	CV8	ME8920CV-SPL	51"	80 deg CV w/ 1-3/8 6 spline MPC	1-3/4 20 spline interfering bolt
81336	CV8	ME8920CV-SPL	51"	80 deg CV w/ 1-3/8 21 spline MPC	1-3/4 20 spline interfering bolt
81332	CV8	ME8920CV-SPL	51"	80 deg CV w/ 1-3/4 20 spline MPC	1-3/4 20 spline interfering bolt
81337	CV8	ME81020CV-SPL	55"	80 deg CV w/ 1-3/8 21 spline MPC	1-3/8 21 spline conical bolt
81338	CV8	ME81020CV-SPL	55"	80 deg CV w/ 1-3/4 20 spline MPC	1-3/8 21 spline conical bolt
81333	CV8	ME81020CV-SPL	55"	80 deg CV w/ 1-3/8 6 spline MPC	1-3/4 20 spline interfering bolt
81334	CV8	ME81020CV-SPL	55"	80 deg CV w/ 1-3/4 20 spline MPC	1-3/4 20 spline interfering bolt
81335	CV8	ME81020CV-SPL	55"	80 deg CV w/ 1-3/8 21 spline MPC	1-3/4 20 spline interfering bolt



WARNING - BE SURE TO USE PROPER LENGTH PTO!!!

It is not implied in our literature that when a size is listed to fit a specific application that the length is correct. Some manufacturers use different lengths; that length should be used.

The applications recommended are to be considered only as a guideline.

Always allow 1/3 of shaft tube to be in at all times.

ALWAYS KEEP SHIELDING IN WORKING ORDER AND IN PLACE



Constant Velocity Eurocardan PTO Assemblies with Shielding



To Fit KMC Peanut Combines

Agmate Part Number	Assembly Description	Series Size	Length Overall	Description
81337	ME8 1020 CV-SPL	CV8	55"	80 deg CV 1 3/8-21 spline MPC yoke on T.E.; 1 3/8-21 spline yoke conical type on I.E.
81338	ME8 1020 CV-SPL	CV8	55"	80 deg CV 1 3/4-20 spline MPC yoke on T.E.; 1 3/8-21 spline yoke conical type on I.E.

To Fit Rhino and Other 15' Flex Wing Cutters

Agmate Part Number	Assembly Description	Series Size	Length Overall	Description
54289	ME8 920 CV-SPL	CV8	51"	80 deg CV 1 3/8-6 spline MPC yoke on T.E.; 1 3/4-20 spline yoke conical type on I.E.
81332	ME8 920 CV-SPL	CV8	51"	80 deg CV 1 3/4-20 spline MPC yoke on T.E.; 1 3/4-20 spline yoke conical type on I.E.
81336	ME8 920 CV-SPL	CV8	51"	80 deg CV 1 3/8-21 spline MPC yoke on T.E.; 1 3/4-20 spline yoke conical type on I.E.

To Fit John Deere, Bush Hog, Kodiak, and other 15' Flex Wing Cutters

Agmate Part Number	Assembly Description	Series Size	Length Overall	Description
81333	ME8 1020 CV-SPL	CV8	55"	80 deg CV 1 3/8-6 spline MPC yoke on T.E.; 1 3/4-20 spline yoke conical type on I.E.
81334	ME8 1020 CV-SPL	CV8	55"	80 deg CV 1 3/4-20 spline MPC yoke on T.E.; 1 3/4-20 spline yoke conical type on I.E.
81335	ME8 1020 CV-SPL	CV8	55"	80 deg CV 1 3/8-21 spline MPC yoke on T.E.; 1 3/4-20 spline yoke conical type on I.E.

To Fit 8' and 10' Rigid Deck Rotary Cutters

Agmate Part Number	Assembly Description	Series Size	Length Overall	Description
34137	ME6 1410 CV-FD2	CV6	70"	80 deg CV 1 3/8-6 spline MPC yoke on T.E.; 1 3/8-6 spline 2 disc friction clutch on I.E.



WARNING - BE SURE TO USE PROPER LENGTH PTO!!!

It is not implied in our literature that when a size is listed to fit a specific application that the length is correct. Some manufacturers use different lengths; that length should be used.

The applications recommended are to be considered only as a guideline.

Always allow 1/3 of shaft tube to be in at all times.

ALWAYS KEEP SHIELDING IN WORKING ORDER AND IN PLACE



Agmate Eurocardan Driveline Table of Contents



Section A	Eurocardan Complete PTO Assemblies with Shielding by style and type
	A1 Smooth Bore yokes - Implement end
	A1 Shear Pin yokes - Implement end
	A2 Slip Clutch style - Implement end
	A3 QD Splined yokes - both Implement and Tractor ends
Section B	Eurocardan Complete PTO Assemblies with Shielding by application
	B1-B3 Rotary Cutters
	B4 Tillers
	B4 Post Hole Diggers
	B5 Flail Mowers
	B5 Disc Mowers
	B5 Hay Tedders
	B5 Fertilizer Spreaders
	B6 Sprayers
	B6 Hydraulic Pumps
	B7 Generators
Section C	Eurocardan Complete Constant Velocity (CV) PTO Assemblies with Shielding
Section D	Eurocardan Complete Constant Velocity (CV) PTO Assemblies with Shielding by application
	D1 Peanut Combines
	D1 Rotary Cutters
Section E	Eurocardan Parts - Standard Drivelines & York style
Section F	Eurocardan Parts - Replacement Shielding
Section G	Eurocardan Parts - Constant Velocity Drivelines, including Shielding
Section H	Problem Solving

Note: The following pages represent Agmate's current offering of stocked Eurocardan driveline assemblies and parts - which does not represent the complete Eurocardan product offering. Other sizes and styles of drivelines, as well as parts, may be available on either a special order or custom stocking program basis. If you have a requirement that you don't see listed, please don't hesitate to contact us.



WARNING - BE SURE TO USE PROPER LENGTH PTO!!!

It is not implied in our literature that when a size is listed to fit a specific application that the length is correct. Some manufacturers use different lengths; that length should be used.

The applications recommended are to be considered only as a guideline.

Always allow 1/3 of shaft tube to be in at all times.

ALWAYS KEEP SHIELDING IN WORKING ORDER AND IN PLACE



DRIVELINE PARTS



AGMATE IS THE EXCLUSIVE NORTH AMERICAN PARTS CENTER

Slip Shaft Tubing/Rounded Triangle Type

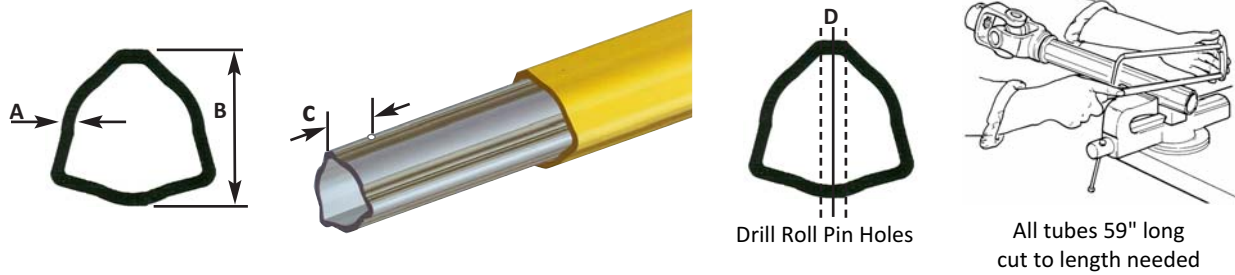

Agmate Part Number	Eurocardan Part Number	Series	Description	Thickness A	Height B	Hole Location C	Hole Size D
33049	1520801	Int 1	Tube	3.5mm	26.5mm	20mm	8mm
33057	1521801	Ext 1	Tube w/2 decals	2.6mm	32.5mm	20mm	8mm
33050	1522801	Int 2	Tube	4mm	29mm	20mm	8mm
33058	1523801	Ext 2	Tube w/2 decals	3.2mm	36mm	20mm	8mm
36731	1523802	Int 3	Tube	3.2mm	36mm	20mm	8mm
33060	1524801	Ext 3 / Ext 4	Tube w/2 decals	3.4mm	43.5mm	20mm	8mm
33052	1525801	Int 4	Tube	4.5mm	36mm	20mm	8mm
33053	1526801	Int 5 / Int 6	Tube	4mm	45mm	22mm	10mm
33061	1527801	Ext 5	Tube w/2 decals	3mm	51.6mm	22mm	10mm
33062	1528801	Ext 6 / Ext 7	Tube w/2 decals	4mm	54mm	22mm	10mm
33055	1529801	Int 7	Tube	5.5mm	45mm	22mm	10mm
36732	1528802	Int 8	Tube	4mm	54mm	22mm	10mm
33064	1530801	Ext 8	Tube w/2 decals	4mm	63mm	22mm	10mm

ROLL PINS

Agmate Part Number	Eurocardan Part Number	Series	Description
36572	6330845	1 Inner	Roll Pin 8mm x 45mm
33045	6330850	1 Ext / 2 Inner	Roll Pin 8mm x 50mm
33046	6330855	2 Ext / 3-4 Inner	Roll Pin 8mm x 55mm
36573	6330860	3-4 Ext	Roll Pin 8mm x 60mm
32485	6330875	5 Ext	Roll Pin 8mm x 75mm - prior to September 1, 1997
36574	6331065	5 Inner	Roll Pin 10mm x 65mm - after September 1, 1997
36559	6331075	5 Ext	Roll Pin 10mm x 75mm - after September 1, 1997
36575	6331070	6 Inner	Roll Pin 10mm x 70mm
32486	6331080	6-7-8 Ext / 8 Inner	Roll Pin 10mm x 80mm
56626	6331090	8 Ext / 8 Inner / ME8	Roll Pin 10mm x 90mm (new style)

SAFETY DECAL FOR EXT TUBES (ALL 59" LENGTHS HAVE 2 APPLIED FROM STOCK)

36722 1140003 All ext tubes Decal "SHIELD MISSING"... be sure all ext tubes are equipped



WARNING - BE SURE TO USE PROPER LENGTH PTO!!!
 It is not implied in our literature that when a size is listed to fit a specific application that the length is correct. Some manufacturers use different lengths; that length should be used.
 The applications recommended are to be considered only as a guideline.
 Always allow 1/3 of shaft tube to be in at all times.



ALWAYS KEEP SHIELDING IN WORKING ORDER AND IN PLACE

Forged Yokes for Slip Tubes

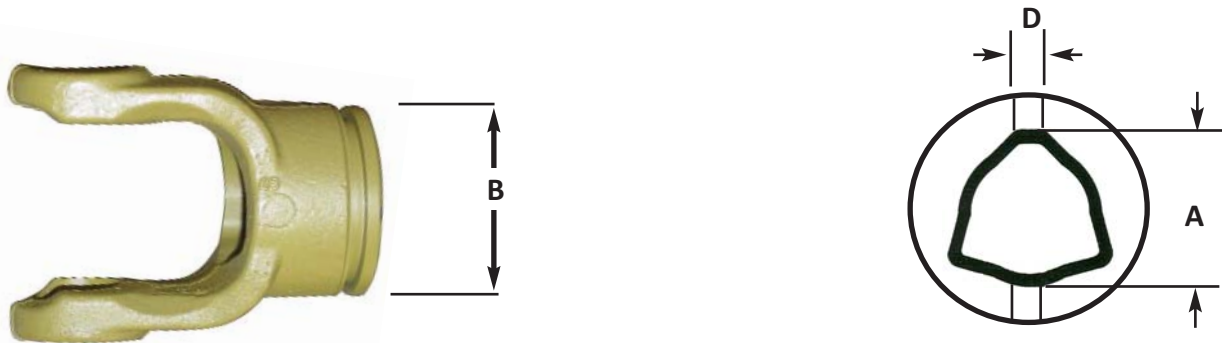

I.E. = Implement End / Internal
T.E. = Tractor End / External

Agmate Part Number	Eurocardan Part Number	Series	Description	Tube Height A	Shield Groove Outside B	Hole Size D
31376	1701027	1	Fork - external tube	32.5mm	47mm	8mm
33035	1702027	2	Fork - external tube	36mm	54mm	8mm
33036	1703027	3	Fork - external tube	43.5mm	61mm	8mm
31378	1704027	4	Fork - external tube	43.5mm	61mm	8mm
31380	1705027	5	Fork - external tube	52.6mm	71mm	10mm
33037	1706027	6	Fork - external tube	54mm	76mm	10mm
33038	1707027	7	Fork - external tube	54mm	76mm	10mm
33039	1708027	8	Fork - external tube	63mm	76mm	10mm
31377	1701029	1	Fork - internal tube	26.5mm	41mm	8mm
33040	1702029	2	Fork - internal tube	29mm	47mm	8mm
33041	1703029	3	Fork - internal tube	36mm	54mm	8mm
31379	1704029	4	Fork - internal tube	36mm	54mm	8mm
31381	1705029	5	Fork - internal tube	45mm	61mm	10mm
33042	1706029	6	Fork - internal tube	45mm	67mm	10mm
33043	1707029	7	Fork - internal tube	45mm	67mm	10mm
33044	1708029	8	Fork - internal tube	54mm	76mm	10mm



WARNING - BE SURE TO USE PROPER LENGTH PTO!!!

It is not implied in our literature that when a size is listed to fit a specific application that the length is correct. Some manufacturers use different lengths; that length should be used.

The applications recommended are to be considered only as a guideline.

Always allow 1/3 of shaft tube to be in at all times.

ALWAYS KEEP SHIELDING IN WORKING ORDER AND IN PLACE



Metric Center Cross Repair Kits

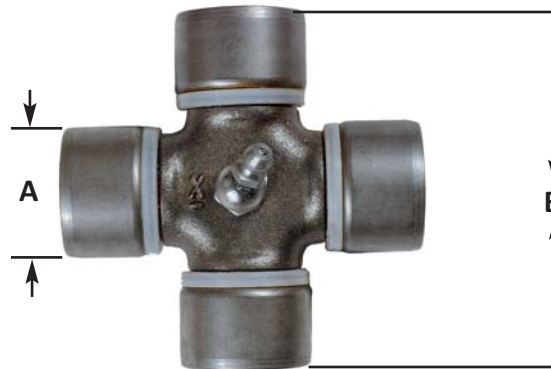

Agmate Part Number	Eurocardan Part Number	Series Size	Description	Cap Diameter A	Cross Height B
31369	1001020	1	Cross Kit Complete	22mm / 55/64"	54mm / 2 1/8"
32190	1002020	2	Cross Kit Complete	23.8mm / 15/16"	61.3mm / 2 13/32"
32191	1003020	3	Cross Kit Complete	27mm / 1 1/16"	70mm / 2 3/4"
31370	1004020	4	Cross Kit Complete	27mm / 1 1/16"	74.6mm / 2 15/16"
31371	1005020	5	Cross Kit Complete	30.2mm / 1 3/16"	80mm / 3 9/64"
32192	1006020	6	Cross Kit Complete	30.2mm / 1 3/16"	92mm / 3 5/8"
32193	1007020	7	Cross Kit Complete	35mm / 1 3/8"	94mm / 3 45/64"
32194	1008020	8	Cross Kit Complete	35mm / 1 3/8"	106.5mm / 4 13/64"
75443	1000020	10	Cross Kit Complete	41mm	118mm / 4 41/64"
35760		All	45° 8mm Zerk for X-kit	Sold Individually	



WARNING - BE SURE TO USE PROPER LENGTH PTO!!!

It is not implied in our literature that when a size is listed to fit a specific application that the length is correct. Some manufacturers use different lengths; that length should be used.

The applications recommended are to be considered only as a guideline.

Always allow 1/3 of shaft tube to be in at all times.

ALWAYS KEEP SHIELDING IN WORKING ORDER AND IN PLACE



Splined Forks Tractor & Implement End Push Pin / Quick Detach

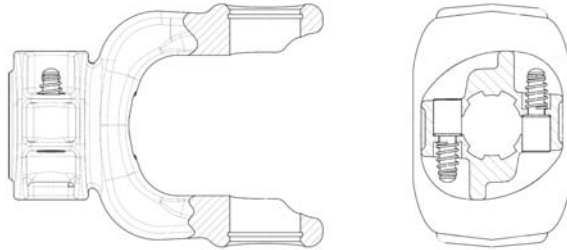

*All series 8 & 10 have (2) release pins on them

Agmate Part Number	Eurocardan Part Number	Series Size	Description	# Of Pins
1 3/8-6 Spline				
31372	1021010	1	1-3/8-6 Spline Push Pin Quick Detach Fork	1
32195	1022010	2	1-3/8-6 Spline Push Pin Quick Detach Fork	1
32196	1023010	3	1-3/8-6 Spline Push Pin Quick Detach Fork	1
31373	1024010	4	1-3/8-6 Spline Push Pin Quick Detach Fork	1
31374	1025010	5	1-3/8-6 Spline Push Pin Quick Detach Fork	1
32197	1026010	6	1-3/8-6 Spline Push Pin Quick Detach Fork	1
32199	1027010	7	1-3/8-6 Spline Push Pin Quick Detach Fork	1
32200*	1028010	8	1-3/8-6 Spline Push Pin Quick Detach Fork	2
1 3/8-21 Spline				
59387	1021015	1	1-3/8-21 Spline Push Pin Quick Detach Fork	1
35269	1022015	2	1-3/8-21 Spline Push Pin Quick Detach Fork	1
36973	1023015	3	1-3/8-21 Spline Push Pin Quick Detach Fork	1
33674	1024015	4	1-3/8-21 Spline Push Pin Quick Detach Fork	1
33543	1025015	5	1-3/8-21 Spline Push Pin Quick Detach Fork	1
33544	1026015	6	1-3/8-21 Spline Push Pin Quick Detach Fork	1
33545	1027015	7	1-3/8-21 Spline Push Pin Quick Detach Fork	1
33546*	1028015	8	1-3/8-21 Spline Push Pin Quick Detach Fork	2
1 3/4-20 Spline				
33929	1025025	5	1-3/4-20 Spline Push Pin Quick Detach Fork	1
33930	1026025	6	1-3/4-20 Spline Push Pin Quick Detach Fork	1
33547	1027025	7	1-3/4-20 Spline Push Pin Quick Detach Fork	1
33548*	1028025	8	1-3/4-20 Spline Push Pin Quick Detach Fork	2
75445*	1020025	10	1-3/4-20 Spline Push Pin Quick Detach Fork	2
Quick Detach Pin Kits				
31375	1581038		1-3/8" Push Pin Kit	
35359	1581039		1-3/4" Push Pin Kit	
65772	1581037		1-3/4" Push Pin Kit fits new enclosed style yokes	



WARNING - BE SURE TO USE PROPER LENGTH PTO!!!

It is not implied in our literature that when a size is listed to fit a specific application that the length is correct. Some manufacturers use different lengths; that length should be used.

The applications recommended are to be considered only as a guideline.

Always allow 1/3 of shaft tube to be in at all times.

ALWAYS KEEP SHIELDING IN WORKING ORDER AND IN PLACE





Splined Forks Tractor & Implement End

Interfering Bolt / Non Interfering Bolt / Plain Splined Yoke



Agmate Part Number	Eurocardan Part Number	Series Size	Description
1-3/8-6 Spline			
35361	1702010	2	1-3/8-6 spline yoke / no holes / fits tedder disc
69268	1704510	4	1-3/8-6 spline yoke / with pin hole
33905	1705272	5	1-3/8-6 spline yoke / no holes 3 7/8" overall / fits flex coupler
34309	1705324	5	1-3/8-6 spline yoke / no holes 4 5/16" overall / fits flex coupler
1-3/4-20 Spline			
35360	1705325	5	1-3/4-20 spline yoke / no holes / fits flex coupler

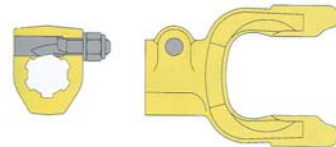

Interfering Bolt Type

Agmate Part Number	Eurocardan Part Number	Series Size	Description
1-3/8-6 Spline			
35888	1108010	8	1 3/8-6 spline yoke / interfering bolt
1-3/4-20 Spline			
74799	1038025	6	1-3/4-20 spline yoke / interfering bolt
36112	1108025	8	1 3/4-20 spline yoke / interfering bolt
39224	6761480	8	Bolt & Nut Kit for 36112 14mm x 80mm
74796	6821483	6	Conical Bolt & Nut Kit for 74799



WARNING - BE SURE TO USE PROPER LENGTH PTO!!!

It is not implied in our literature that when a size is listed to fit a specific application that the length is correct. Some manufacturers use different lengths; that length should be used.

The applications recommended are to be considered only as a guideline.

Always allow 1/3 of shaft tube to be in at all times.

ALWAYS KEEP SHIELDING IN WORKING ORDER AND IN PLACE



Smooth Bore Forks



Rotary Cutter Shear Pin Forks
 1-3/8" Smooth Bore with 1/2" Shear Pin Hole
 Held on with snap ring on input shaft groove

Agmate Part Number	Eurocardan Part Number	Series Size	Description
47205	1073138	3	Fits Series 3
32201	1074033	4	Fits Series 4
32202	1075541	5	Fits Series 5
32203	1076951	6	Fits Series 6

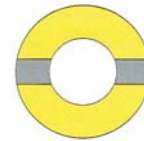

Post Hole Digger Shear Pin Forks
 1-1/4" smooth bore with 3/8" shear pin hole and 1/4"-20 unc s.s. hole
 Held on with set screws in yoke that fit into shaft groove, not included

Agmate Part Number	Eurocardan Part Number	Series Size	Description
32204	1071040	1	Fits Series 1
32205	1073040	3	Fits Series 3
32206	1074040	4	Fits Series 4

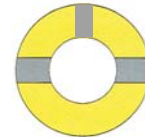

Miscellaneous Smooth Bore Equipment End Forks
 For Sprayer Pumps and Other Applications

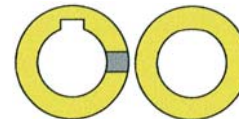

Agmate Part Number	Eurocardan Part Number	Series Size	Description
54601	1061033	1	3/4" smooth yoke w/ 3/16" keyway / 5/16-18 unc set screw
54600	1061032	1	15/16" smooth yoke w/ 1/4" keyway / 5/16-18 unc set screw
54599	1061031	1	5/8" smooth yoke w/ 3/16" keyway 5/16-18 unc set screw
54598	1061026	1	1" smooth yoke w/ 1/4" keyway / 3/8-16 set screw hole
35819	1063015	3	30mm bore (1 3/16") / 1/4" keyway / set screw hole
53516	1064015	4	30mm (3/16") bore / 5/16" keyway / 10mm set screw hole
32233	1064829	4	1" smooth yoke with 1/4" keyway / (2) 1/4" set screw holes



WARNING - BE SURE TO USE PROPER LENGTH PTO!!!
 It is not implied in our literature that when a size is listed to fit a specific application that the length is correct. Some manufacturers use different lengths; that length should be used.
 The applications recommended are to be considered only as a guideline.
 Always allow 1/3 of shaft tube to be in at all times.



ALWAYS KEEP SHIELDING IN WORKING ORDER AND IN PLACE



FD0 Slip Clutch Parts

Light Duty 2 Disc - 6020 In. Lb. Torque for use with Series 4

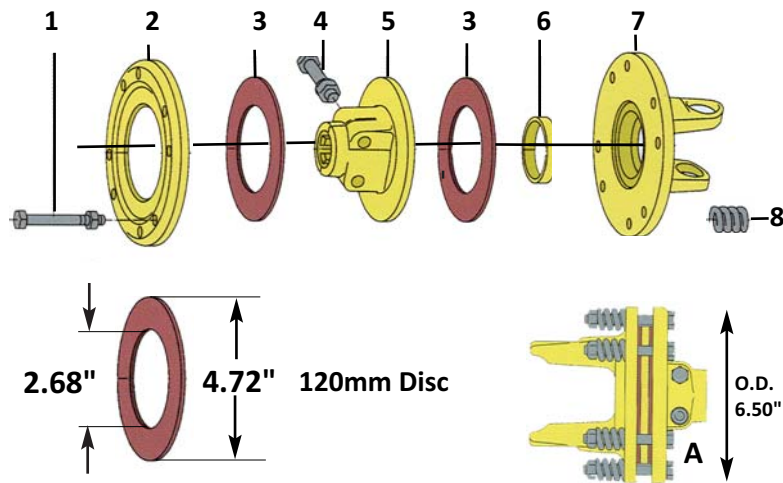

CH Spring Settings			
Spring Height	Nm	FD0 Torque in.-lb.	ft.-lb.
29/1.14	230	2040	170
28/1.10	410	3630	300
27/1.06	530	4690	390
26/1.02	680	6020	500

Reference Number	Agmate Part Number	Eurocardan Part Number	Description
A	40225	1334030	Slip Clutch FD0 T L Fork (Series Size 4) 1 3/8-6
1	40224	6001075	Slip Clutch Tension Spring Bolt 10mm x 75mm (FD0)
2	40222	1334000	Slip Clutch FD0 Outer Plate
3	40219	1804000	120mm Friction Disc (FD0) O.D. 4.72" I.D. 2.68"
4	54157	6821271	Slip Clutch 65mm Conical Bolt Kit 12mm
5	40220	1704016	Slip Clutch 1 3/8-6 Hub (FD0)
6	40221	1704017	Sleeve
7	40945	1704021	Slip Clutch Flange Yoke (FD0) #4
8	32498	1215012	Tension Spring 6mm

Friction Disc

153mm fits Belleville Clutch BC2-BC4

Agmate Part Number	Eurocardan Part Number	Description
73635	1806010	153mm Disc fits Belleville Clutch

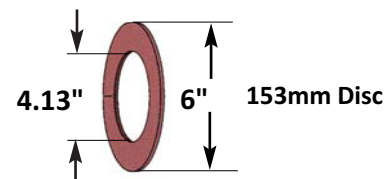

WARNING - BE SURE TO USE PROPER LENGTH PTO!!!

It is not implied in our literature that when a size is listed to fit a specific application that the length is correct. Some manufacturers use different lengths; that length should be used.

The applications recommended are to be considered only as a guideline.

Always allow 1/3 of shaft tube to be in at all times.

ALWAYS KEEP SHIELDING IN WORKING ORDER AND IN PLACE





FD1 / FDS1 Slip Clutch Parts

Standard 2 Disc - 7950 In. Lb. Torque For Use With Series 4/5/6

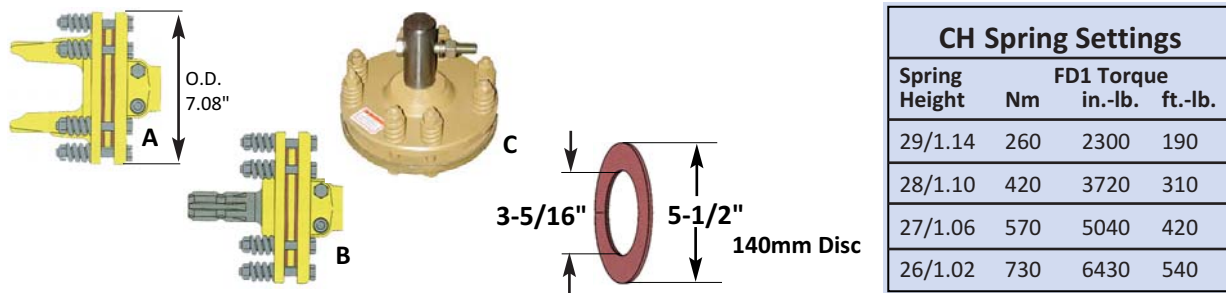

CH Spring Settings			
Spring Height	Nm	FD1 Torque	
		in.-lb.	ft.-lb.
29/1.14	260	2300	190
28/1.10	420	3720	310
27/1.06	570	5040	420
26/1.02	730	6430	540

Reference Number	Agmate Part Number	Eurocardan Part Number	Series Size	Description
------------------	--------------------	------------------------	-------------	-------------

Complete FD1 Assembly Fork

A	32207	1344018	4	Complete FD1 torque limiter with yoke 1 3/8-6
A	32208	1345018	5	Complete FD1 torque limiter with yoke 1 3/8-6
A	32209	1346018	6	Complete FD1 torque limiter with yoke 1 3/8-6

Complete FDS1 Attachments

B	31951	1356104		Slip Clutch Attachment w/ 1 3/8-6 splines
C	32323	1356242		Slip Clutch Attachment w/ 1 3/8 smooth shaft & hub

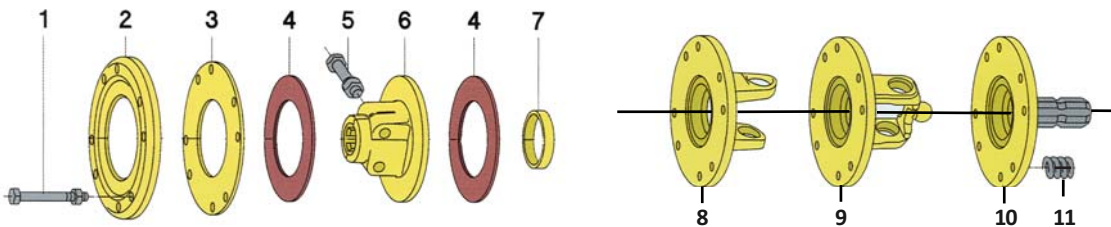

Parts For FD1 / FDS1

1	82960	6691085		Spring bolt kit w/nut 10 x 85mm (FD 1/2)
2	32487	1135007		Pressure plate - outer
3	32551	1135008		Pressure plate - inner 180mm
4	31953	1805010		Friction disc - 140mm (5.5") 3 5/16" center hole
5	32505	6141270		Bolt only 12mm x 70mm
	33996	6411212		Lock washer 12mm
	32506	6410112		Nut 12mm
6	32489	1705005		Hub 1 3/8-6 splines
	33910	1706308		Hub smooth 1 3/8" for FDS1 attachment
	69283	1705047		Hub 1-3/8-21 splines for FD1
7	32490	1705009		Sleeve
8	32491	1704006	4	Flange w/ yoke for series 4
	32492	1705006	5	Flange w/ yoke for series 5
9	33911	1706309		Flange w/ smooth shaft for FDS1 attachment
10	33912	1706100		Flange w/ splined shaft for FDS1 attachment
11	32498	1215012		Spring tension (also used on FDS1 attachment) 6mm



WARNING - BE SURE TO USE PROPER LENGTH PTO!!!

It is not implied in our literature that when a size is listed to fit a specific application that the length is correct. Some manufacturers use different lengths; that length should be used.

The applications recommended are to be considered only as a guideline.

Always allow 1/3 of shaft tube to be in at all times.

ALWAYS KEEP SHIELDING IN WORKING ORDER AND IN PLACE



Eurocardan PM14 Complete Shields for series 1-2-3-4



Complete Shields To Fit Up To 1210mm (47-1/2") x to x PTO Assemblies

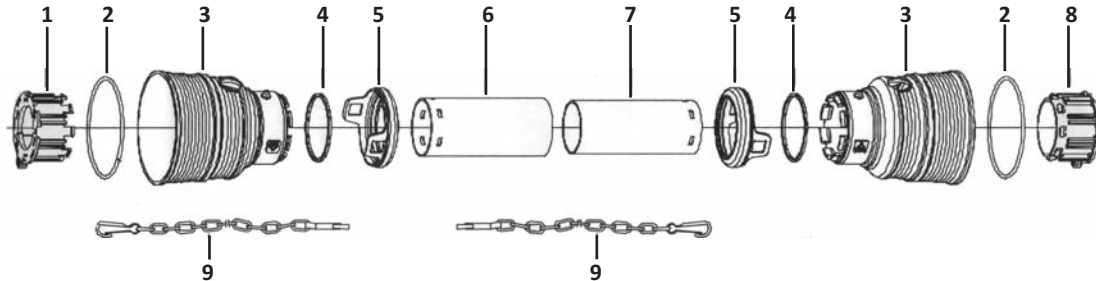

Agmate Part Number	Eurocardan Part Number	Description	Fits Max Lgth X-X	Fits Series PTO
Shield With 2 Standard Cones				
36726	90SL1101	Complete shield w/series 1 bearings - P14	1210	1
73302	96SS2100	Complete shield w/series 2 bearing - PM 14	1210	2
71040	96SL4099	Complete shield w/series 4 bearings - PM 14	1210	3-4
<p>**Long cone can ONLY be used on shear pin/splined yokes (tractor or implement end) Cover for the slip clutch/shear flange MUST BE PROVIDED by manufacturer on gear box</p>				
Shield With 1 standard cone / 1 short cone (for slip clutch type drive lines)				
73297		Short Cone...add to price	All	1-2-3-4
Shield With 2 long cones (for splined or smooth yoke both ends)				
73296		Long Cone...add to price	All	1-2-3-4

****NOTE: SHIELDS ARE FOR UP TO 1210MM X-X DRIVE LINES . . . CUT TUBES TO FIT**

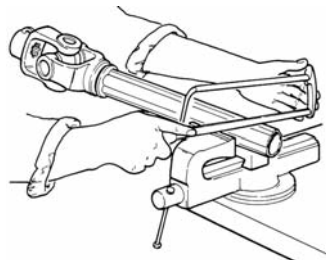

ASSEMBLE THE SHIELDS ON EACH HALF, THEN CUT THE TUBES THE SAME LENGTH AS THE SLIP TUBES. MAKE SURE THEY DO NOT COME TOGETHER AND BIND WHEN THE 2 HALVES ARE ASSEMBLED.



WARNING - BE SURE TO USE PROPER LENGTH PTO!!!

It is not implied in our literature that when a size is listed to fit a specific application that the length is correct. Some manufacturers use different lengths; that length should be used. The applications recommended are to be considered only as a guideline. Always allow 1/3 of shaft tube to be in at all times.



ALWAYS KEEP SHIELDING IN WORKING ORDER AND IN PLACE



FD2 Slip Clutch Parts (160mm Disc)

Heavy Duty 2 Disc - 10,600 In. Lb. Torque For Use with Series 5/6/7

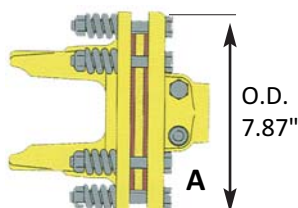

CH Spring Settings			
Spring Height	FD2 Torque		
	Nm	in.-lb.	ft.-lb.
29/1.14	310	2740	230
28/1.10	520	4600	380
27/1.06	720	6370	530
26/1.02	940	8320	690

Reference Number	Agmate Part Number	Eurocardan Part Number	Series Size	Description
Complete FD2 Assembly Fork				
A	33030	1385018	5	Complete FD2 torque limiter with yoke 1 3/8-6
A	32210	1386018	6	Complete FD2 torque limiter with yoke 1 3/8-6
A	36104	1406028	6	Complete FD2 torque limiter with yoke 1 3/4-20
A	54156	1386016	6	Complete FD2 torque limiter with yoke 1 3/8-6 IB
A	74798	1406216	6	Complete FD2 torque limiter with yoke 1 3/4-20 IB

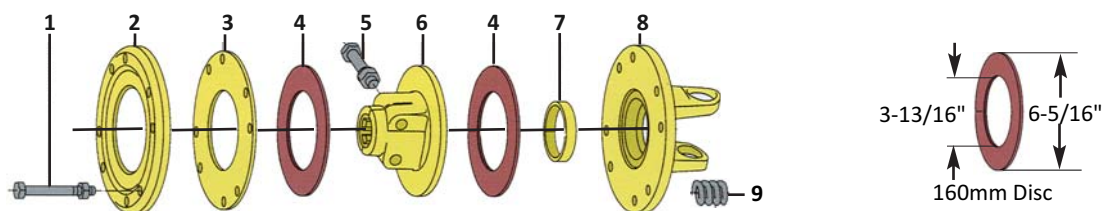

Parts for FD2				
1	82960	6691085		Spring bolt kit w/nut 10 x 85mm (FD 1/2)
	39224	6761480		Bolt & nut kit for 1 3/4 hub 14mm x 80mm
2	32495	1138007		Pressure plate - outer
3	32552	1138008		Pressure plate - inner 200mm
4	31971	1808010		Friction disc - 160mm (6 5/16") 3 13/16" ctr hole
5* (1-3/8)	32505	6141270		Bolt only 12mm x 70mm
	33996	6412112		Lock washer 12mm
	32506	6410112		Nut 12mm
5*	74797	6821484		Bolt & nut kit fits 74798
5* (1-3/4)	39224	6761480		Bolt & nut kit fits 36104
5*	54157	6821271		12 x 65mm conical bolt kit fits 54156
6* (1-3/8)	32497	1708005		Hub 1-3/8-6 splines
6* (1-3/4)	34064	1706314		Hub 1-3/4-20 splines
6* (1-3/8)	73780	1708121		Hub 1-3/8-21 splines
6* (1-3/8)	54155	1708907		Hub 1-3/8-6 splines conical bolt 54156
7	32490	1705009		Sleeve
8	33031	1705041	5	Flange w/ yoke for series 5
	32493	1706033	6	Flange w/ yoke for series 6
	33553	1708006	8	Flange w/ yoke for series 8
9	32498	1215012	5/6/7	Tension spring 6mm



WARNING - BE SURE TO USE PROPER LENGTH PTO!!!

It is not implied in our literature that when a size is listed to fit a specific application that the length is correct. Some manufacturers use different lengths; that length should be used.

The applications recommended are to be considered only as a guideline.

Always allow 1/3 of shaft tube to be in at all times.

ALWAYS KEEP SHIELDING IN WORKING ORDER AND IN PLACE



FD4 Slip Clutch Parts (4 Disc 160mm Disc)



Heavy Duty 12,850 In. Lb. Torque Series 6 15,050 In. Lb. Torque Series 7 & 8

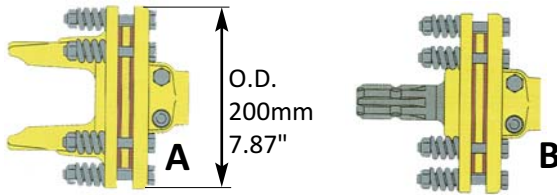

CH Spring Settings			
Spring Height	FD4 Torque		
	Nm	in.-lb.	ft.-lb.
29/1.14	710	6280	520
28/1.10	1190	10530	880
27/1.06	1530	13540	1130
26/1.02	1860	16460	1370

Reference Number	Agmate Part Number	Eurocardan Part Number	Series Size	Description
Complete FD4 Assembly Fork				
A	32387	1466030	6	Complete FD4 torque limiter with yoke 1-3/8-6
A	34574	1446037	6	Complete FD4 torque limiter with yoke 1-3/4-20
A	33550	1468031	8	Complete FD4 torque limiter with yoke 1-3/8-6
A	34149	1448034	8	Complete FD4 torque limiter with yoke 1-3/4-20
A	32646	1448032	8	Complete FD4 torque limiter with yoke 1-3/4-6

Complete FDS4 Attachment				
B	36065	1456030	6/7/8	Comp FDS4 slip clutch attachment w/male shaft 1 3/8-6

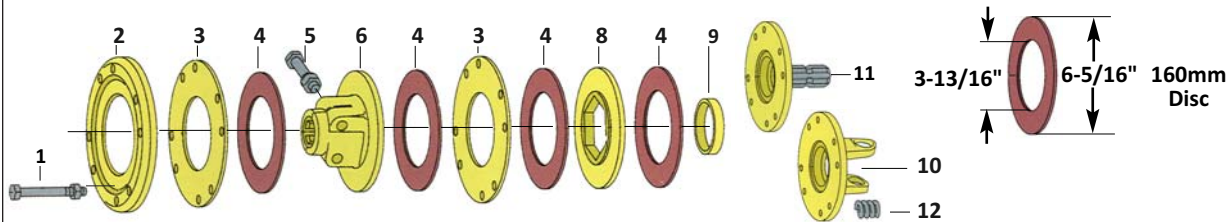

Parts for FD4 Only				
1	35030	6691010		Bolt 10mm x 100mm for tension spring w/nut
2	32495	1138007		Pressure plate - outer
3	32552	1138008		Pressure plate - inner 200mm
4	31971	1808010		Friction disc - 160mm (6-5/16") 3-13/16" center hole
5* (1-3/8)	32505	6141270		Bolt only 12mm x 70mm
	33996	6411212		Lock washer 12mm
	32506	6410112		Nut 12mm
5* (1-3-4)	39224	6761480		Bolt Kit 14mm x 80mm
6* (1-3/8)	33551	1708018		Hub 1-3/8-6 splines (FD4)
6* (1-3/8)	34150	1705032		Hub 1-3/8-6 splines (FD3)
6* (1-3/4)	34575	1706313		Hub 1-3/4-20 splines (FD4)
6	69284	1708021		Hub 1-3/8-21 splines (FD4)
8	34153	1708034		Inner spacer sleeve
9	32490	1705009		Sleeve
10	32493	1706033	6	Flange w/ yoke for series 6
	33553	1708006	8	Flange w/ yoke for series 8
11	36541	1706101		Splined shaft/plate
12	32498	1215012	6	Tension spring



WARNING - BE SURE TO USE PROPER LENGTH PTO!!!

It is not implied in our literature that when a size is listed to fit a specific application that the length is correct. Some manufacturers use different lengths; that length should be used.

The applications recommended are to be considered only as a guideline.

Always allow 1/3 of shaft tube to be in at all times.

ALWAYS KEEP SHIELDING IN WORKING ORDER AND IN PLACE



Complete LC Shear Pin Forks

Complete Yoke Assembly 1-3/8-6 Spline

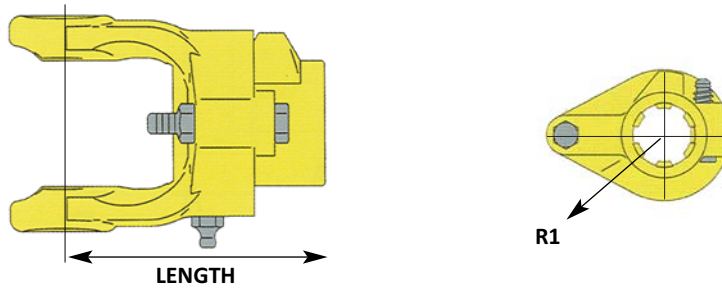

Agmate Part Number	Eurocardan Part Number	Series Size	Used On	B Length	In. Lb. Torque	R1 Diameter
Complete LC Shear Pin Forks						
33034	1484037	4	LC4	4-7/32"	15000	2-31/64"

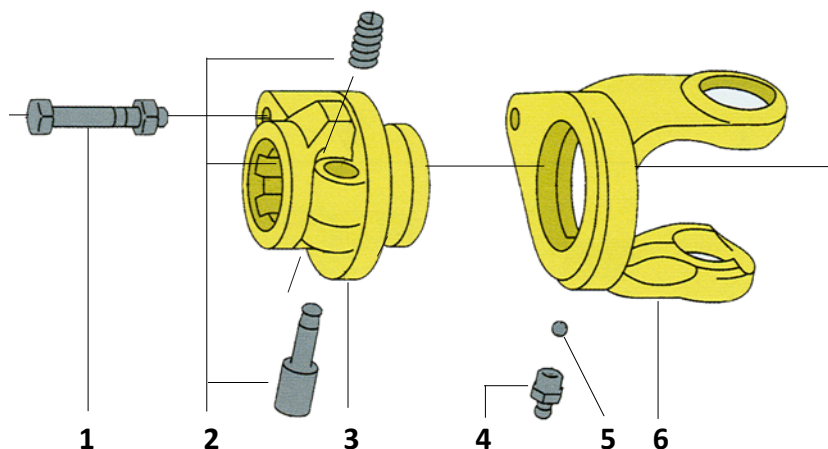

Reference Number	Agmate Part Number	Eurocardan Part Number	Series Size	Description	Qty. Req'd	Used On
Parts for LC Shear Pin Flanges - limited inventories (special orders)						
1	36288	1480845	3 & 4	Shear bolt 8mm x 45mm w/nut		LC3/4
2	31375	1581038	all	QD pin assembly	1	All
3	36286	1484035	4	Hub flange w/push pin	1	LC4
4	36289	6560010		Grease zerk	1	All
5	36290	6863114	4/5	Ball bearing	1	4/5
6	36287	1704036	4	Yoke only	1	LC4



WARNING - BE SURE TO USE PROPER LENGTH PTO!!!

It is not implied in our literature that when a size is listed to fit a specific application that the length is correct. Some manufacturers use different lengths; that length should be used.

The applications recommended are to be considered only as a guideline.

Always allow 1/3 of shaft tube to be in at all times.

ALWAYS KEEP SHIELDING IN WORKING ORDER AND IN PLACE



Metal Collar Quick Release Yokes

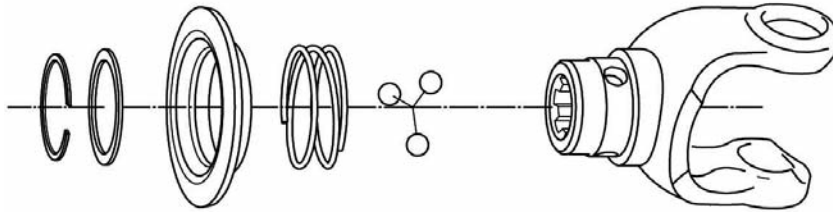

Agmate Part Number	Eurocardan Part Number	Description	Size
54158	1011013	1-3/8-6 (#1) Metal Collar QR	1
60259	1012013	1-3/8-6 (#2) Metal Collar QR	2
60260	1014013	1-3/8-6 (#4) Metal Collar QR	4
59389	1015013	1-3/8-6 (#5) Metal Collar QR	5
54159	1016013	1-3/8-6 (#6) Metal Collar QR	6
54597	1018013	1-3/8-6 (#8) Metal Collar QR	8
59390	1015018	1-3/8-21 (#5) Metal Collar QR	5
60261	1016018	1-3/8-21 (#6) Metal Collar QR	6
60262	1018018	1-3/8-21 (#8) Metal Collar QR	8
60263	104227	Metal Collar Repair Kit	All



WARNING - BE SURE TO USE PROPER LENGTH PTO!!!

It is not implied in our literature that when a size is listed to fit a specific application that the length is correct. Some manufacturers use different lengths; that length should be used.

The applications recommended are to be considered only as a guideline.

Always allow 1/3 of shaft tube to be in at all times.

ALWAYS KEEP SHIELDING IN WORKING ORDER AND IN PLACE





LN Pawl Type Torque Limiter Parts List

LN2 Series 1 - 5,700 In. Lb. Torque / LN2 Series 2 up - 7,050 In. Lb. Torque

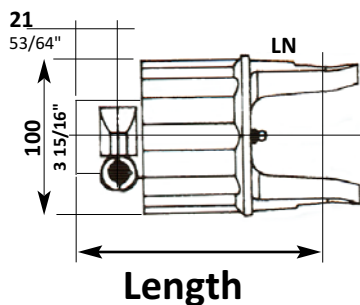

Agmate Part Number	Eurocardan Part Number	Series Size	Description	Length
Complete Pawl Fork				
32322	1622250	2	LN2 Pawl with yoke w/ 1 3/8-6 spline	5.59"
57467	1644250	4	LN3 Pawl with yoke w/ 1 3/8-6 spline	6.81"

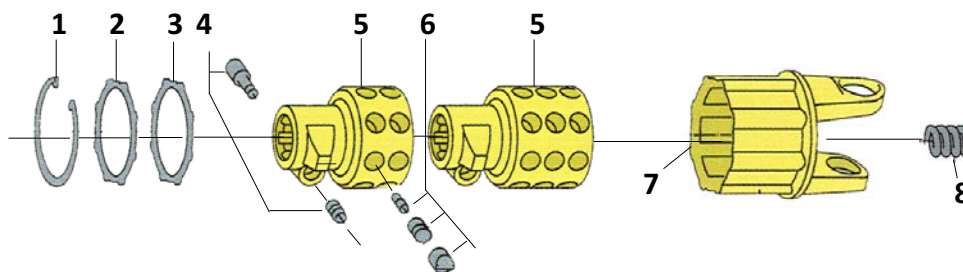

Reference Number	Agmate Part Number	Eurocardan Part Number	Series Size	Description
Parts for LN Forks				
1	32501	6320080		Snap ring
2	33888	1131225		Closure ring
3	33889	1781226		Anti-dust ring
4	31375	1581038		QD pin assembly
5	33886	1702245		Hub for 2 pawl w/ 1-3/8-6 spline
	49281	1643245		Hub for 3 pawl
6	35031	1601146		Pawl kit w/springs, requires 8 kits per row
7	33890	1622248	2	Yoke 1-3/8-6 spline
8	35251	6560006		Grease Zerk



WARNING - BE SURE TO USE PROPER LENGTH PTO!!!

It is not implied in our literature that when a size is listed to fit a specific application that the length is correct. Some manufacturers use different lengths; that length should be used.

The applications recommended are to be considered only as a guideline.

Always allow 1/3 of shaft tube to be in at all times.

ALWAYS KEEP SHIELDING IN WORKING ORDER AND IN PLACE



Gear Box Connector Shaft Assemblies

Complete with Flex Coupler - Series 5

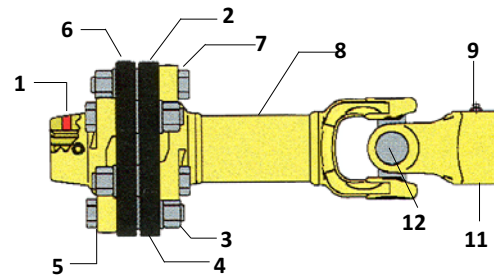
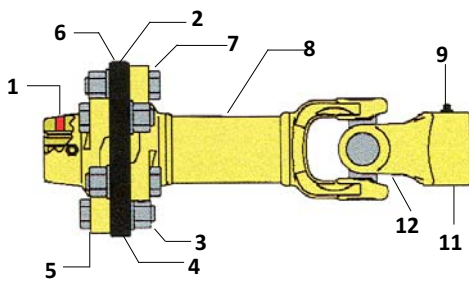

Agmate Part Number	Eurocardan Part Number	Description
33231	8155033	Complete Single Pad (12.8" overall) 1 3/8-6 both ends
36949	7155006	Complete Single Pad (12.75" overall) 1 3/8-6 both ends (yoke end interfering bolt type)
36950	7155005	Complete Double Pad (16.75" overall) 1 3/8-6 both ends (yoke end interfering bolt type)
56204	7155018	Complete Double Pad (16.75" overall) 1 3/4-20 both ends (special order)
34249	8155042	Complete Double Pad (17.5" overall) 1 3/8-6 pad end / 1 3/4-20 interfering bolt yoke end
34138	8155041	Complete Double Pad (18.5" overall) 1 3/8-6 both ends

Reference Number	Agmate Part Number	Eurocardan Part Number	Description	Quantity Required	Used On
1	33899	1705268	Splined Flange 1 3/8-6 Spline	1	ALL
	35889	1705277	Splined Flange 1 3/4-20 Spline	1	ALL
	51987	1705250	Smooth Flange Hub (1 3/8 rd)	1	ALL
2	33931	1785273	Pads	varies 1 or 2	ALL
3	33997	3381660	16 x 60 Bolt (single pad)	6	33231
	33900	3381680	16 x 80 Bolt (double pad)	6	ALL
4	33901	1535275	Bushing	varies 6 or 12	ALL
5	33902	3930016	16mm Flat Washer	varies 6 or 12	ALL
6	33903	1235287	Shaped Washer	6	ALL
7	33904	3647016	Self Locking Nut 16mm	6	ALL
8	34253	1005311	Tube and Flange Yoke	1	33231
	49282	1005223	Tube and Flange Yoke	1	36949
	49283	1005222	Tube and Flange Yoke	1	36950
	49284	1005329	Tube and Flange Yoke	1	34249
	36101	1005327	Tube and Flange Yoke	1	34138
	36100	1005325	Tube and Flange Yoke	1	33983
	34254	1005317	Tube and Flange Yoke	1	33232
9	33905	1705272	Yoke (1-3/8 6 Spline)	1	ALL
	34309	1705324	Extended Yoke (1-3/8-6 Spline)	1	34138
	49286	1105010	Yoke (1 3/8-6 interfering bolt)	1	36949/50
	49952	1105015	Yoke (1 3/8-21 interfering bolt)	1	ALL
	35360	1705325	Yoke (1 3/4-20 Spline)	1	34249
11	35251	6560006	Grease Zerk	1	ALL
12	31371	1005020	Center Cross Kit Series 5	1	ALL (except 56204)



WARNING - BE SURE TO USE PROPER LENGTH PTO!!!

It is not implied in our literature that when a size is listed to fit a specific application that the length is correct. Some manufacturers use different lengths; that length should be used.

The applications recommended are to be considered only as a guideline.

Always allow 1/3 of shaft tube to be in at all times.

ALWAYS KEEP SHIELDING IN WORKING ORDER AND IN PLACE



Over-running Clutch / QD Pin Type

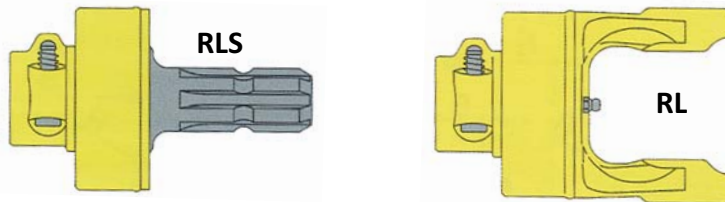

Agmate Part Number	Eurocardan Part Number	Type	Description
31949	1516127	RLS1	1 3/8-6 to 1 3/8-6 QD Pin
32439	1516113	RLS1	1 1/8-6 to 1 3/8-6 QD Pin
38217	1504226	RL1	Yoke Type Series #4
38218	1745226	RL2	Yoke Type Series #5

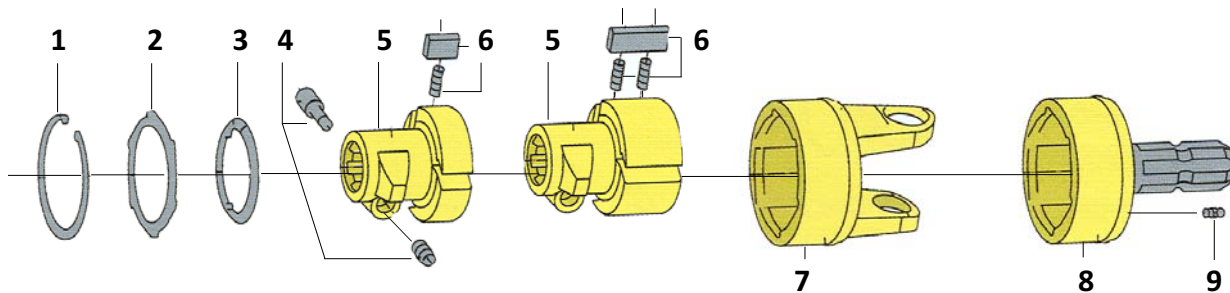

Reference Number	Agmate Part Number	Eurocardan Part Number	Description	Used On
1	32501	6320080	Snap ring	ALL
2	32502	1133008	Sealing ring	ALL
3	32503	1783009	Anti Dust Ring	ALL
4	31375	1581038	QD Pin Assembly	ALL
5	33894	1503007	Hub for 1 3/8-6 to 1 3/8-6	RL1/RLS1
	33895	1503018	Hub for 1 1/8-6 to 1 3/8-6	RL1/RLS1
	33896	1746107	Hub for 1 3/8-6 to 1 3/8-6	RL2/RLS2
6	42174	1505026	Pawl/Spring Kit (requires 3 per unit)RL1/RLS1	
	32500	1745108	Pawl/Spring Kit (requires 3 per unit)RL2/RLS2	
7	38301	1504225	Yoke and ext body	RL1/RLS1
	38302	1745225	Yoke and ext body	RL2/RLS2
8	33897	1516110	Splined shaft for 1 3/8-6 housing	RL1/RLS1
	33898	1756112	Splined shaft for 1 3/8-6 housing	RL2/RLS2
9	35251	6560006	Grease Zerk	ALL



WARNING - BE SURE TO USE PROPER LENGTH PTO!!!

It is not implied in our literature that when a size is listed to fit a specific application that the length is correct. Some manufacturers use different lengths; that length should be used.

The applications recommended are to be considered only as a guideline.

Always allow 1/3 of shaft tube to be in at all times.

ALWAYS KEEP SHIELDING IN WORKING ORDER AND IN PLACE



Eurocardan PM14 Shield Parts for series 1-2-3-4

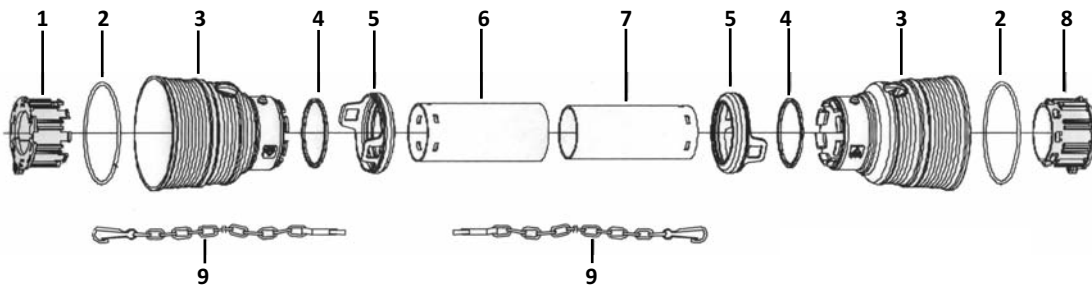

Reference Number	Agmate Part Number	Eurocardan Part Number	Description	Qty. Req'd	Fits Max Lgth X-X	Fits Series PTO
Bearing Locks For All Shields						
	35064	1781210	Tube Bearing - Outer #1	1	All	
1	73291	1782710	Tube Bearing - Outer #2	1	All	
	73295	1784710	Tube Bearing - Outer #3-4	1	All	
	35067	1781211	Tube Bearing -Inner #1	1	All	
8	73288	1782711	Tube Bearing - Inner #2	1	All	
	73292	1784711	Tube Bearing - Inner #3-4	1	All	
4	73300	1211735	Safety Ring	2	All	
5	73299	1881709	Safety Sleeve	2	All	1-2-3-4
2	73301	1211733	Stiffening Ring	2	All	1-2-3-4
Soft Outer Cone						
3	73298	1781723	Cone-Standard Covers Cross		All	1-2-3-4
10	73297	1781722	Cone-Short-Covers up to the Cross-use w/slip clutch		All	1-2-3-4
12	73296	1781724	Cone-Long-Covers Cross and Yoke		All	1-2-3-4
6	73290	1772100	Outer Tube		1210	1-2
6	73294	1772099	Outer Tube		1210	3-4
7	73289	1731100	Inner Tube for up to 1210mm		1210	1-2
7	73293	1731099	Inner Tube for up to 1210mm		1210	3-4
9	33994	1006065	Anti-Rotation Chain		All	
Miscellaneous Chains/Decals						
	36721	1140001	Decal Outer Shield ("DANGER")		All	

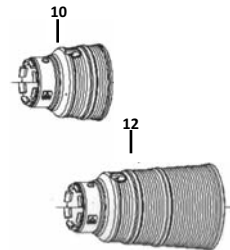

WARNING - BE SURE TO USE PROPER LENGTH PTO!!!

It is not implied in our literature that when a size is listed to fit a specific application that the length is correct. Some manufacturers use different lengths; that length should be used.

The applications recommended are to be considered only as a guideline.

Always allow 1/3 of shaft tube to be in at all times.

ALWAYS KEEP SHIELDING IN WORKING ORDER AND IN PLACE



Eurocardan PM57 Complete Shields for series 5-6-7

Complete Shields To Fit Up To 1540mm X to X PTO Assemblies

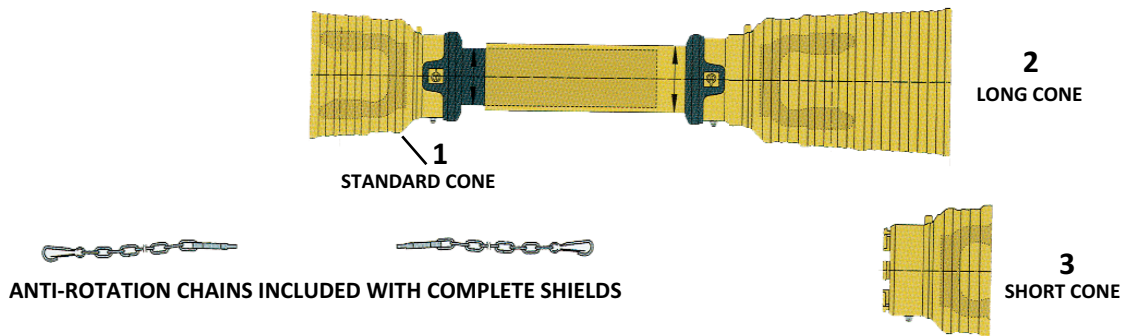

Reference Number	Agmate Part Number	Eurocardan Part Number	Description	Fits Max Length X-X	Fits Series PTO
Shield With 1 Standard Cone / 1 Short Cone (for slip clutch type drive lines) add to above for short cone, change out long cone one implement end					
1	39588	90SC6064	Shield for slip clutch w/series 6-7 bearings	910	6-7
	39589	90SC6094	Complete shield w/6-7 bearings	1210	6-7
Shield With 2 Standard Cones only if equipment is furnished with permanent shielding add to above for standard cone, change out long cone on implement end					
3	59388	90SS6127	Complete shield w/5 bearings	1540	5
	56628	90SS6129	Complete shield w/6-7 bearings	1540	6/7

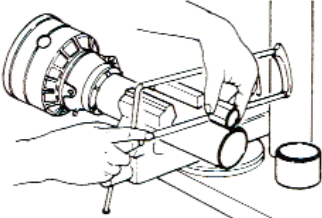

****NOTE: SHIELDS ARE FOR UP TO 910mm, 1210MM AND 1540MM DRIVE LINES...CUT TUBES TO FIT**

ASSEMBLE THE SHIELDS ON EACH HALF, THEN CUT THE TUBES THE SAME LENGTH AS THE SLIP TUBES. MAKE SURE THEY DO NOT COME TOGETHER AND BIND WHEN ASSEMBLED.



WARNING - BE SURE TO USE PROPER LENGTH PTO!!!
 It is not implied in our literature that when a size is listed to fit a specific application that the length is correct. Some manufacturers use different lengths; that length should be used.
 The applications recommended are to be considered only as a guideline.
 Always allow 1/3 of shaft tube to be in at all times.



ALWAYS KEEP SHIELDING IN WORKING ORDER AND IN PLACE

Eurocardan PM57 Shield Parts for series 5-6-7



Complete Shields To Fit Up To 1410mm X to X PTO Assemblies

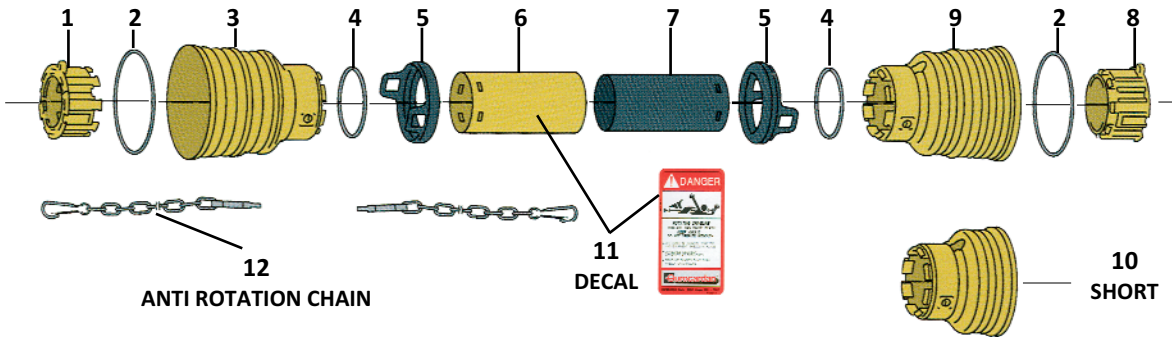

Ref. Number	Agmate Part Number	Eurocardan Part Number	Description	Fits Max Length X-X	Fits Series PTO
Bearing Locks For All Shields					
1	36521	1785710	Tube Bearing-Outer #5	All	5
	36522	1786710	Tube Bearing-Outer #6-7	All	6-7
8	36519	1785711	Tube Bearing-Inner #5	All	5
	36520	1786711	Tube Bearing-Inner #6-7	All	6-7
Cones with Stiffening Ring					
3	36517	1785703	Cone-Standard Covers Cross	All	5-6-7
9	36516	1785704	Cone-Long-Covers Cross and Yoke	All	5-6-7
10	36518	1785702	Cone-Short-Covers up to the cross-use w/ slip clutch	All	5-6-7
2	36523	1215733	Stiffening Ring (replacement only)	All	5-6-7
Safety Locks					
4	36524	1215735	Stop Snap Ring - takes 2 per shield	All	5-6-7
5	36525	1885709	Safety Sleeve - takes 2 per shield	All	5-6-7
Tubes Only - cut to length to fit needs					
6	56655	1776114	Outer tube for up to 1410 mm x-x yellow (45") w/decals	1410	5-6-7
7	56656	1877114	Inner tube for up to 1410 mm x-x black (45")	1410	5-6-7
Miscellaneous - Chains/Decals					
11	36721	1140001	Decal "DANGER"	All Outer Tubes	
12	33994	1006065	Anti-Rotation Chain	All	



WARNING - BE SURE TO USE PROPER LENGTH PTO!!!

It is not implied in our literature that when a size is listed to fit a specific application that the length is correct. Some manufacturers use different lengths; that length should be used.

The applications recommended are to be considered only as a guideline.

Always allow 1/3 of shaft tube to be in at all times.

ALWAYS KEEP SHIELDING IN WORKING ORDER AND IN PLACE





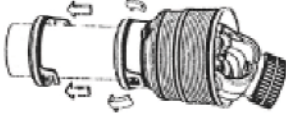
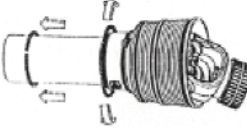
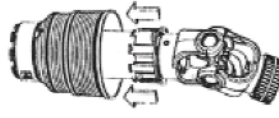
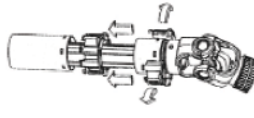

DISMANTLING INSTRUCTIONS

 <p>1. REMOVE SAFETY SLEEVE.</p>	 <p>2. REMOVE SNAP RING FROM SLOT.</p>	 <p>3. SLIDE CAP AWAY FROM LOCK.</p>	 <p>4. WIDEN THE BEARING AND TAKE OFF TUBE AND YOKE.</p>
---	---	--	---

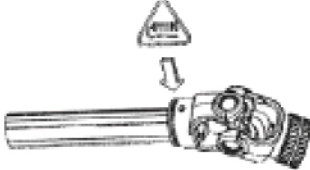
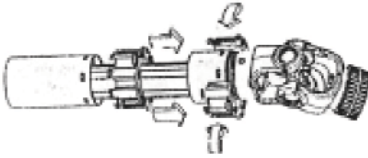
ASSEMBLING INSTRUCTIONS

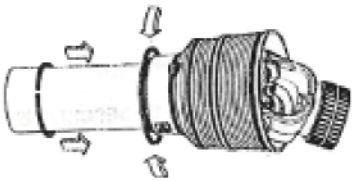
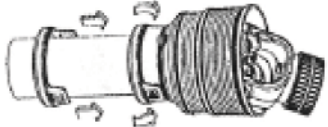
 <p>1. GREASE THE SEAT ON THE FORK</p>	 <p>2. PUT THE BEARING IN THE SLOT ON THE YOKE WHILE HOOKING ONTO THE TUBE.</p>	 <p>3. INSERT THE CONE ONTO THE BEARING, MAKING SURE THE SLOTS MATCH UP AND THE CHAIN HOOK IS IN THE SLOT INTENDED FOR IT.</p>
 <p>4. PUT THE SNAP RING IN THE GROOVE, WHICH IS FORMED WITH THE CAP AND BEARING IF PROPERLY ALIGNED.</p>	 <p>5. SLIDE THE SAFETY RING OVER THE SNAP RING AND ATTACH TO THE PROJECTIONS ON THE CONE.</p>	



WARNING - BE SURE TO USE PROPER LENGTH PTO!!!

It is not implied in our literature that when a size is listed to fit a specific application that the length is correct. Some manufacturers use different lengths; that length should be used.

The applications recommended are to be considered only as a guideline.

Always allow 1/3 of shaft tube to be in at all times.

ALWAYS KEEP SHIELDING IN WORKING ORDER AND IN PLACE



Series 4 ME Style Constant Velocity

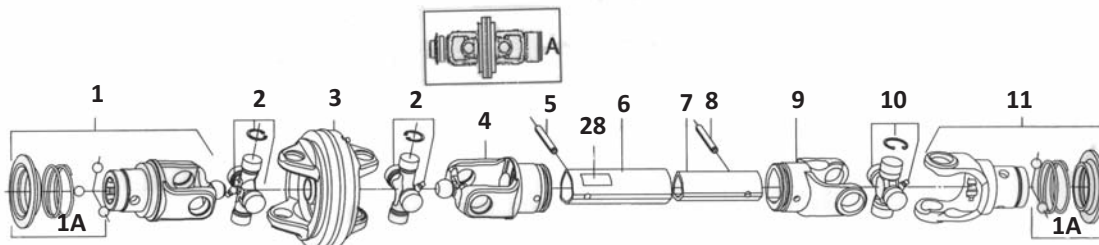

Reference Number	Agmate Part Number	Eurocardan Part Number	Description	Qty. Req'd
A	56641	7104422	G04 Homokinetic Assy w/ 1 3/8-6 T.E.	1
1	58912	1004875	Yoke Metal Pull Collar CV 1 3/8-6	1
2	56210	1004840	Cross Kit G04	2
3	56643	1004831	Center Homokinetic Joint G04	1
4	56644	1004827	Ext Tube Yoke G04	1
5	36573	6330860	Roll Pin 8mm x 60mm	1
6	33060	1524801	Ext Tubing #4 (cut to length & drill pin hole)	1
7	33052	1525801	Int Tubing #4 (cut to length & drill pin hole)	1
8	33046	6330855	Pin roll 8mm x 55mm	1
9	31379	1704029	Inner Tube Yoke	1
10	31370	1004020	Cross Kit Series 4	1
11	60260	1014013	Yoke Metal Pull Collar 1 3/8-6	1
12	36722	1140003	Decal Tube (Shield Missing)	1



WARNING - BE SURE TO USE PROPER LENGTH PTO!!!

It is not implied in our literature that when a size is listed to fit a specific application that the length is correct. Some manufacturers use different lengths; that length should be used.

The applications recommended are to be considered only as a guideline.

Always allow 1/3 of shaft tube to be in at all times.

ALWAYS KEEP SHIELDING IN WORKING ORDER AND IN PLACE



PM14 Shield For ME4 and GM4 CV Assembly For Series 4 Only

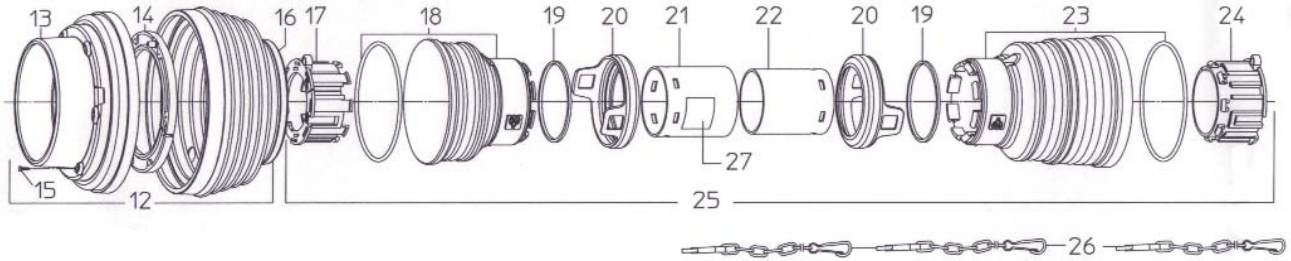

Reference Number	Agmate Part Number	Eurocardan Part Number	Description	Qty. Req'd
12	83923	9490401	Wide Angle Protection	1
14	40228	1780430	Bearing Soft Cone	1
15	33557	6280313	Self Threading Screw	6
17	73295	1784710	Outer Tube Bearing	1
18		1781701	Extra Short Cone	1
19	73300	1211735	Stop Ring	2
20	73299	1881709	Safety Sleeve	2
21	73294	1772099	Outer Tube Shield	1
22	73293	1731099	Inner Tube Shield	1
23	73298	1781723	Standard Cone	1
24	73292	1784711	Inner Tube Bearing	1
25	56645	90CS4059	Complete Protection up to CV joint	1
26	33994	1006065	Anti-Rotation Chain	3
27	36721	1140001	Outer Decal	1
28	36722	1140003	Inner Decal	1



WARNING - BE SURE TO USE PROPER LENGTH PTO!!!

It is not implied in our literature that when a size is listed to fit a specific application that the length is correct. Some manufacturers use different lengths; that length should be used.

The applications recommended are to be considered only as a guideline.

Always allow 1/3 of shaft tube to be in at all times.

ALWAYS KEEP SHIELDING IN WORKING ORDER AND IN PLACE



Series 6 ME Style Constant Velocity

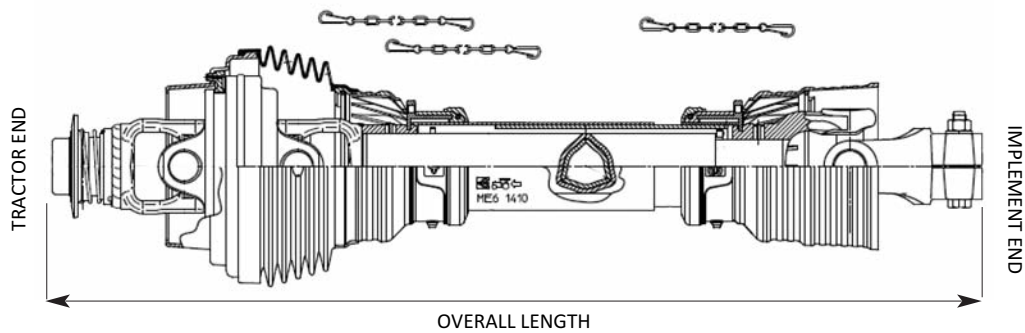

Reference Number	Agmate Part Number	Eurocardan Part Number	Description	Qty. Req'd
A	56647	7106522	GO6 Homokenetic Assy w/1 3/8-6 T.E.	1
1	56648	1006865	Yoke metal pull collar 1 3/8-6	1
	56649	1006866	Yoke metal pull collar 1 3/8-21	OPT
1a	56650	1006814	Yoke Metal Pull Collar 1 3/4-20	OPT
1b	60263	1004227	Repair Kit for metal pull collar	1
2	56208	1006830	Cross Kit GO6	2
3	56651	1006831	Center Homokinetic Joint GO6	1
4	56652	1006827	Ext Tube Yoke GO6	1
5	32486	6331080	Roll Pin 10mm X 80mm	1
6	33062	1528801	Ext Tubing #6 (cut to length & drill pin hole)	1
7	33053	1526801	Int Tubing #6 (cut to length & drill pin hole)	1
8	36575	6331070	Roll Pin 10mm X 70mm	1
9	33042	1706029	Inner Tube Yoke	1
10	32192	1006020	Cross Kit Series 6	1
11	74799	1036025	Yoke 1 3/4-20 interferring bolt	1
11a	74797	6821484	Conical Bolt kit fits 1 3/4-20 yoke	1
12	36722	1140003	Decal tube "SHIELD MISSING"	1



WARNING - BE SURE TO USE PROPER LENGTH PTO!!!

It is not implied in our literature that when a size is listed to fit a specific application that the length is correct. Some manufacturers use different lengths; that length should be used.

The applications recommended are to be considered only as a guideline.

Always allow 1/3 of shaft tube to be in at all times.

ALWAYS KEEP SHIELDING IN WORKING ORDER AND IN PLACE



PM57 Shield For ME6 CV Assembly

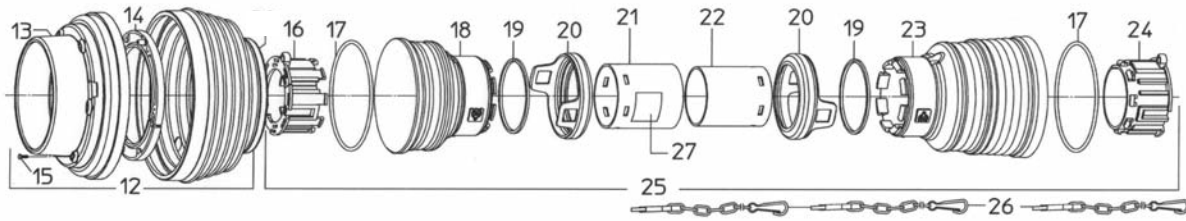

Reference Number	Agmate Part Number	Eurocardan Part Number	Description	Qty. Req'd
12	72195	9490601A	Wide Angle Protection	1
14	57195	1786801	Bearing Soft Cone	1
15	33557	6280313	Self Threading Screw	6
16	36522	1786710	Outer Tube Bearing	1
17	36523	1215733	Stiffening Ring	2
18	36518	1785702	Short Cone	1
19	36524	1215735	Stop Ring	2
20	36525	1885709	Safety Sleeve	2
21	56655	1776114	Outer Tube Shield	1
22	56656	1877114	Inner Tube Shield	1
23	36517	1785703	Standard Cone	1
24	36520	1786711	Inner Tube Bearing	1
25	56653	90CS6114	Complete Protection up to CV Joint	1
26	33994	1006065	Anti-Rotation Chain	3
27	36721	1140001	Outer Decal	1
28	36722	1140003	Inner Decal	1



WARNING - BE SURE TO USE PROPER LENGTH PTO!!!

It is not implied in our literature that when a size is listed to fit a specific application that the length is correct. Some manufacturers use different lengths; that length should be used.

The applications recommended are to be considered only as a guideline.

Always allow 1/3 of shaft tube to be in at all times.

ALWAYS KEEP SHIELDING IN WORKING ORDER AND IN PLACE



Series 8 ME Style Constant Velocity

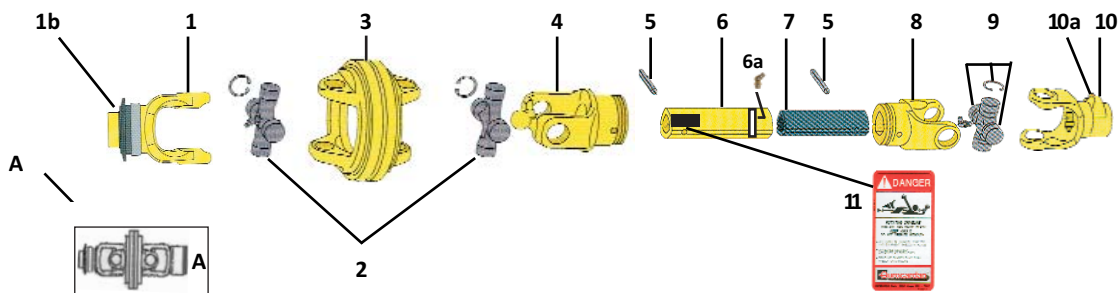

Reference Number	Agmate Part Number	Eurocardan Part Number	Description	Qty. Req'd
A	56657	7108522	GO8 Homokenetic Assy w/1 3/8-6 TE	1
1	56658	1008865	Yoke metal pull collar 1 3/8-6	1
1*	56659	1008866	Yoke metal pull collar 1 3/8-21	1
1*	56660	1008878	Yoke MPC 1 3/4-20	1
1b	60263	1004227	Repair Kit for Metal Pull Collar	1
2	56209	1008830	Cross Kit GO8	2
3	56661	1008831	Center Homokinetic Joint GO8	1
4	56662	1008827	Ext Tube Yoke GO8	1
5	56626	6331090	Roll Pin 10 X 90	2
6	33064	1550901	Ext Tubing 59" drill & cut to length	1
6a	35251	6560006	Grease zerk	1
7	36732	1551072	Inner Tubing 59" drill & cut to length	1
8	33044	1708029	Inner Tube Yoke	1
9	32194	1008020	Cross Kit Series 8	1
10	35888	1108010	Yoke 1 3/8-6 Interfering Bolt	1
	36112	1108025	Yoke 1 3/4-20 Interfering Bolt	1
10a	74797	6821484	Bolt Kit for 1-3/4-20 Yoke	1
11	36722	1140003	Decal Tube "SHIELD MISSING"	1



WARNING - BE SURE TO USE PROPER LENGTH PTO!!!

It is not implied in our literature that when a size is listed to fit a specific application that the length is correct. Some manufacturers use different lengths; that length should be used.

The applications recommended are to be considered only as a guideline.

Always allow 1/3 of shaft tube to be in at all times.

ALWAYS KEEP SHIELDING IN WORKING ORDER AND IN PLACE



PM80E Shield For ME8 CV Assembly

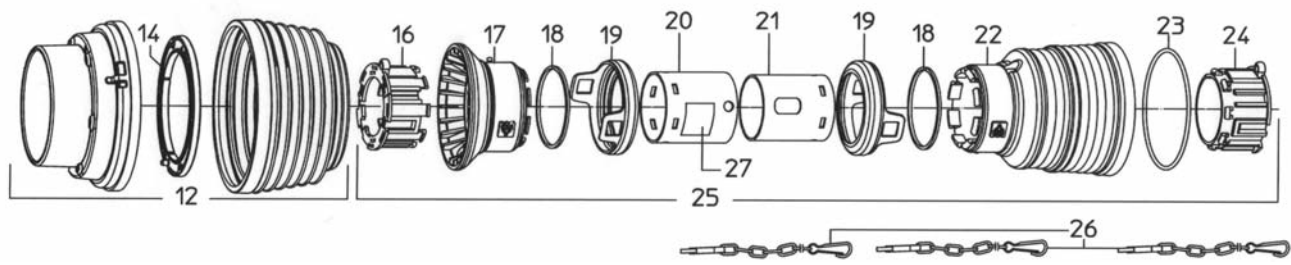

Reference Number	Agmate Part Number	Eurocardan Part Number	Description	Qty. Req'd
12	56666	9490600	Wide Angle Protection (cover for CV only)	1
14	35261	1786527	Bearing Soft Cone	1
11	35257	6280313	Self Threading Screw	6
16	56634	1788016	Bearing Outer Shield Tube P80E	1
17	56631	1788022	Cone Short P80E	1
18	56637	1218035	Stop Ring P80E	2
19	56638	1888009	Safety Sleeve P80E	2
20	56640	1778902	Tube Outer Shield	1
21	56639	1879902	Tube Inner Shield	1
23	56636	1218033	Stiffening Ring	1
22	56632	1788023	Cone Standard P80E	1
24	56635	1788017	Bearing Inner Tube P80E	1
25	65773	96CS8904	Complete P80E shield fits ME8 1440 (cut to size)	1
26	33994	1006065	Anti-Rotation Chain	3
27	36721	1140001	Decal Outer Shield Tube ("DANGER")	1



WARNING - BE SURE TO USE PROPER LENGTH PTO!!!

It is not implied in our literature that when a size is listed to fit a specific application that the length is correct. Some manufacturers use different lengths; that length should be used.

The applications recommended are to be considered only as a guideline.

Always allow 1/3 of shaft tube to be in at all times.

ALWAYS KEEP SHIELDING IN WORKING ORDER AND IN PLACE



Problem Solving

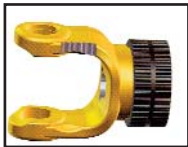

Yoke Arm Wear - Excessive working angles on swivels:

- Reduce swivel working angles
- Disconnect the drive for angles greater than 45°, for simple joints, and 80° for joints with wide angle



Deformation of Yoke Arms - Excessive torque peaks:

- Avoid engaging the drive suddenly with transmission on load
- Avoid excessive overloading during operation
- Avoid sudden motion interruption in machines with high inertia
- Check the torque limiting device to make sure it is working properly



Wear of Cross Pins - Excessive working power:

- Avoid exceeding the power and speed scheduled for transmission

Insufficient lubrication:

- Lubricate the cross and the other points on the shaft according to the manufacturer's instructions



Cross Pin Breakage - Excessive torque peaks:

- Avoid engaging the drive suddenly with transmission under load
- Avoid excessive overloads during operation
- Avoid sudden motion interruption in machines with high inertia
- Check functioning of torque limiter

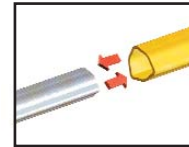

Telescopic Tubes Decoupling - Excessive lengthening of transmission:

- Check to be sure transmission length is suitable for the application
- Be sure that in maximum transmission extension conditions, there is sufficient tube overlap as described by the manufacturer
- Check that the maximum length does not exceed the manufacturer's specifications

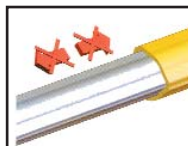

Telescopic Tube Seizure - Insufficient lubrication, tubes overheating:

- Lubricate the tubes and the other points on the shaft according to the manufacturer's instructions

Tube Deformation:
See Deformation of Tubes (right)



Premature Wear of the Protection Bearings - Insufficient lubrication:

- Lubricate the protection bearings and the other points on the shaft according to the manufacturer's instructions



Uncoupling of protection or breakage of anti-rotation chain - incorrect anti-rotation chain fixing:

- Ensure that the chain is fixed to special points which permit articulation of the transmission in all working directions

Interfering Protection:
Check that the transmission never comes into contact with parts of the tractor or machine



Deformation of Tubes - Excessive torque peaks:

- Check that the shaft dimension is adequate to the power to be transmitted
- Avoid engaging the drive suddenly under load
- Avoid excessive overloading during operation
- Avoid sudden motion interruption in machines with high inertia
- Check functioning of torque limiting device
- Check that the transmission does not come into contact with loader or machine parts during operation or maneuvers
- In shafts with wide-angle joints, check that during maneuvers the joint is not forced beyond the prescribed angle



Wear of Telescopic Tubes - Insufficient lubrication:

- Lubricate the tubes and the other points of the shaft in accordance with the manufacturer's instructions.

Insufficient Tube Overlap:

- Be sure that in maximum transmission extension conditions, there is sufficient tube overlap as described by the manufacturer
- Check that the maximum length does not exceed the manufacturer's specifications



Safety Device Locking - Long period of non use in damp surroundings:

- Dismantle the safety device, clean its internal parts, lubricate where required and reassemble.
- For long periods of non-use, keep the device under cover in a dry place

Excessive Tightening Of Adjustment Elements, where applicable:

- Do not lock the adjustment elements completely

GREASING

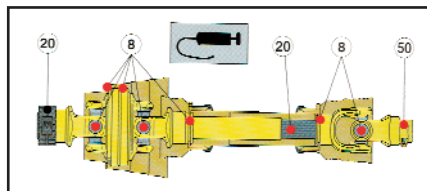

Grease the shaft at the points indicated above as per hours shown. Use lithium grease for extreme pressure (EP).

OVERLAP

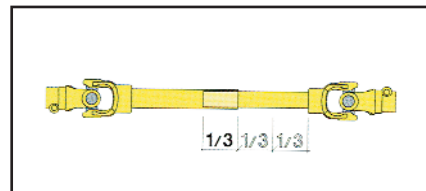

Be sure that in the various work conditions there is an overlap of the telescopic tubes of at least 1/3 of their length.

Agmate Economy Driveline



Table Of Contents

Section I Agmate Economy Driveline Complete PTO Assemblies with Shielding by style and type

I1	Smooth Bore yokes - Implement end
I1	Shear Pin yokes - Implement end
I1	QD Splined yokes - both Implement and Tractor ends
I1	Slip Clutch style - Implement end
I2	CV Style

Section J Agmate Economy Driveline Complete PTO Assemblies with Shielding by application

J1-J2	Rotary cutters
J2	Fertilizer Spreaders
J2	Finishing Mower
J2	Generator
J3	Post hole diggers
J3	Rotary tiller
J3	Pond aerator

Section K Agmate Economy Driveline Parts

Section L Problem Solving

Note: The following pages represent Agmate's current offering of stocked Economy driveline assemblies and parts. Other sizes and styles of drivelines, as well as parts, may be available on either a special order or custom stocking program basis. If you have a requirement that you don't see listed, please don't hesitate to contact us.

Horsepower Ratings - Economy Line

Economy Line	HP @ 540 RPM	HP @ 1000 RPM
Series #1	16 hp	25 hp
Series #2	21 hp	31 hp
Series #4	35 hp	55 hp
Series #5	47 hp	74 hp
Series #6	64 hp	100 hp



BE SURE TO USE PROPER LENGTH PTO!!!

It is not implied in our literature that when a certain size is listed that the length is correct. Some manufacturers use different lengths; that length should be used. The applications recommended are to be considered only as a guide line.

Always allow 1/3 of shaft tube to be in at all times.

ALWAYS KEEP SHIELDING IN WORKING ORDER AND IN PLACE



Other items may be available via special order. Please contact us for additional information

Terms and Conditions



Prices subject to change without prior notice - Please ask for quote.

Warehouse: FOB Selma, NC Best price is available with a \$1,000 minimum order. 10% surcharge added for orders under \$1,000. Exceptions: PTO parts

Half Container: FOB Selma, NC This price is available on 1/2 truck load orders. All items may be combined to meet the 20,000 lb. requirement. Standard lead time is 120 days; but shorter lead times are subject to product availability.

Full Container: FOB Port This price is available on all containers shipped directly from the supplier. Items may be combined to meet the 38,000 lb. container requirement. Lead time is minimum 120 days.

Terms: Net 10 days

Warranty: Agmate sells only the highest quality products available in today's market. All Agmate products are guaranteed to be free of defects in workmanship and materials. All Agmate products are guaranteed to fit the machine for which they are intended. Agmate will not honor any claim for warranty on any part that has been altered in any way by anyone else but Agmate. All claims for warranty must be made in writing to Dick Jones & Associates, Inc., the Agmate representatives.

Please direct all claims to:
Dick Jones & Associates, Inc.
PO Box 3835
Cleveland, TN 37320-3835

You will then be advised as to the disposition of the parts. Do not ship any parts back to Agmate or Dick Jones & Associates, Inc. unless requested to do so. Settlements of warranty claims will be in the form of a credit memo to be used towards future purchases at Agmate or free replacement of the part will be shipped immediately if part is in stock. If after receiving written notice, Agmate determines the parts should be returned for inspection, you will be notified to return some or all of the parts. The parts should be returned freight prepaid unless otherwise approved. If after inspection it is determined that the parts are defective, credit will be issued for parts and reimbursement for your freight charges. Agmate does not authorize any repairs in the field or labor charges for replacements. Agmate reserves the right to alter this warranty and make product changes without notice.

Items: Cross reference #'s do not imply original OEM parts. Weights are estimated.

PTOs: BE SURE TO USE THE PROPER LENGTH PTO! It is not implied in this literature that when a certain size is listed that the length is correct. Some manufacturers use different lengths; that length should be used. The applications recommended are to be considered only as a guideline. Always allow 1/3 of shaft tube to be in at all times. Be sure to keep shielding in place and use proper parts to fit assembly designed for. Replace all worn or stretched parts. Make sure shielding is always in place.



Agmate Economy Drivelines



Complete PTO Assemblies w/ Shielding

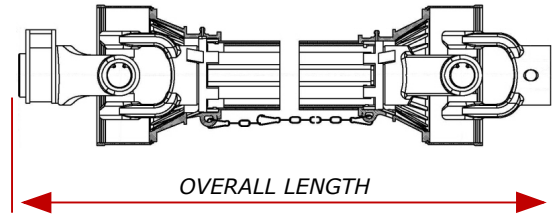

Smooth Bore & Shear Pin Implement End

Part #	Series	Collapsed	Extended	Tractor Yoke	Implement Yoke
84348	1	27.75"	37.23"	1 3/8"-6 spline	15/16" rd w/ keyway/ s.s.
102265	1	51"	76"	1 3/8"-6 spline	1 1/4" rd w/ 3/8" shear pin
89800	4	32.6"	40.65"	1 3/8"-6 spline	1 3/8" rd w/ 1/2" shear pin
89803	4	37.8"	48.32"	1 3/8"-6 spline	1 3/8" rd w/ 1/2" shear pin
89367	4	42.5"	55.37"	1 3/8"-6 spline	1 3/8" rd w/ 1/2" shear pin
89804	4	47.2"	62.5"	1 3/8"-6 spline	1 3/8" rd w/ 1/2" shear pin
89806	4	51.5"	68.9"	1 3/8"-6 spline	1 1/4" rd w/ 3/8" shear pin
89805	4	57.09"	77.26"	1 3/8"-6 spline	1 3/8" rd w/ 1/2" shear pin
68383	6	47.9"	73.98"	1 3/8"-6 spline	1 1/2" smooth bore w/ 3/8" key way & 3/8" 16 unc set screw
81587	6	56"	73.4"	1 3/8"-6 spline	1 3/8" rd w/ 1/2" shear pin

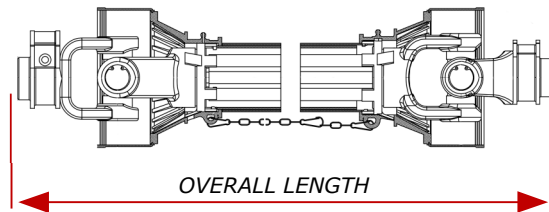

Splined Yoke Implement End

Part #	Series	Collapsed	Extended	Tractor Yoke	Implement Yoke
89795	1	27"	33"	1 3/8"-6 spline	1 3/8"-6 spline
89798	4	40.39"	51.9"	1 3/8"-6 spline	1 3/8"-6 spline
89799	4	53"	70"	1 3/8"-6 spline	1 3/8"-6 spline
84123	6	28"	35"	1 3/8"-6 spline	1 3/8"-6 spline
68381	6	44.5"	62.68"	1 3/8"-6 spline	1 3/8"-6 spline
102974	6	53"	70"	1 3/8"-6 spline	1 3/8"-6 spline

BE SURE TO USE PROPER LENGTH PTO!!!

It is not implied in our literature that when a certain size is listed that the length is correct. Some manufacturers use different lengths; that length should be used. The applications recommended are to be considered only as a guide line.

Always allow 1/3 of shaft tube to be in at all times.

ALWAYS KEEP SHIELDING IN WORKING ORDER AND IN PLACE



Agmate Economy Drivelines



Complete PTO Assemblies w/ Shielding

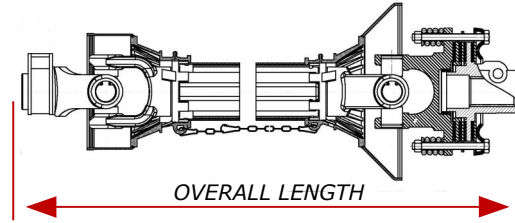

Slip Clutch Implement End

Part #	Series	Collapsed	Extended	Tractor Yoke	Implement Yoke
89364	4	34"	44.2"	1 3/8"-6 spline	1 3/8"-6 spline (FD0) 2 disc slip clutch (160mm)
89797	4	43"	58.54"	1 3/8"-6 spline	1 3/8"-6 spline (FD1) 2 disc slip clutch (180mm)
102268	4	34.6"	44"	1 3/8"-6 spline	1 3/8" sm bore (FD1) 2 disc slip clutch (180mm)
89807	5	37.72"	46.65"	1 3/8"-6 spline	1 3/8"-6 spline (FD2) 2 disc slip clutch (200mm)
89366	5	45.9"	58.9"	1 3/8"-6 spline	1 3/8"-6 spline (FD2) 2 disc slip clutch (200mm)
81588	6	45.9"	58.9"	1 3/8"-6 spline	1 3/4"-20 spline 4 disc slip clutch (180mm)
90647	6	54.2"	70.74"	1 3/8"-6 spline	1 3/8"-6 spline (FD2) 2 disc slip clutch (200mm)
105045	6	54.2"	70.74"	1 3/8"-6 spline	1 3/4"-20 spline (FD2) 2 disc slip clutch (200mm)
90649	6	61"	80.74"	1-3/4"-20 spline (I.B.)	1 3/4"-20 spline (FD2) 2 disc slip clutch (200mm) (I.B.)

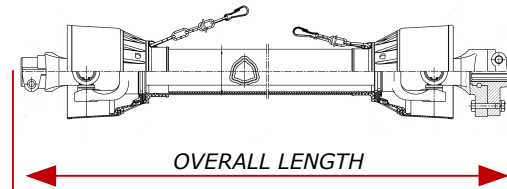

Shear Pin Bolt Flange Yoke

Part #	Series	Collapsed	Extended	Tractor Yoke	Implement Yoke
90557	6	50.03"	60"	1-3/8- 6 Spline (I.B.)	1-3/8-6 splined LC shear pin bolt flange yoke

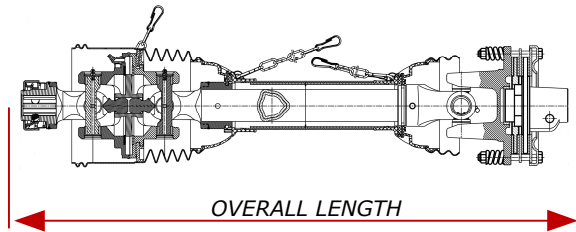

Constant Velocity

Part #	Series	Collapsed	Extended	Tractor Yoke	Implement Yoke
90650	6	73"	100.8"	1-3/8- 6 Spline	1 3/8"-6 spline (FD2) 2 disc slip clutch (200mm)



BE SURE TO USE PROPER LENGTH PTO!!!
 It is not implied in our literature that when a certain size is listed that the length is correct. Some manufacturers use different lengths; that length should be used. The applications recommended are to be considered only as a guide line.
 Always allow 1/3 of shaft tube to be in at all times.
ALWAYS KEEP SHIELDING IN WORKING ORDER AND IN PLACE



Agmate Economy Drivelines



Complete PTO Assemblies w/ Shielding

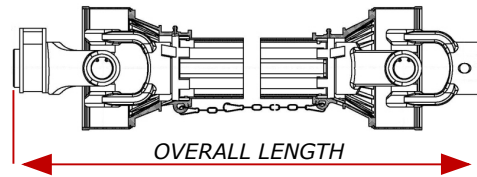

Rotary Cutter (Shear Pin)

Part #	Series	Used On	Collapsed	Extended	Tractor Yoke	Implement Yoke
89800	4	4' Lift Type	32.6"	40.65"	1 3/8"-6 spline	1 3/8" rd w/ 1/2" shear pin
89803	4	4 & 5 Lift Type	37.8"	48.32"	1 3/8"-6 spline	1 3/8" rd w/ 1/2" shear pin
89367	4	5' & 6' Lift Type	42.5"	55.37"	1 3/8"-6 spline	1 3/8" rd w/ 1/2" shear pin
89804	4	6' Lift Type	47.2"	62.5"	1 3/8"-6 spline	1 3/8" rd w/ 1/2" shear pin
89805	4	5' & 6' Pull Type	57.09"	77.26"	1 3/8"-6 spline	1 3/8" rd w/ 1/2" shear pin
81587	6	6' & 7' Pull Type	56"	73.4"	1 3/8"-6 spline	1 3/8" rd w/ 1/2" shear pin

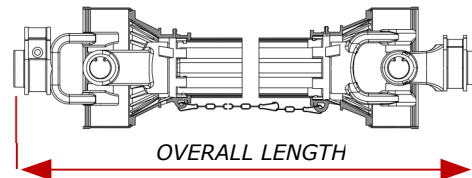

Rotary Cutter (Splined)

Part #	Series	Used On	Collapsed	Extended	Tractor Yoke	Implement Yoke
68381	6	6' Lift Type	44.5"	62.68"	1 3/8"-6 spline	1 3/8"-6 spline
102974	6	7' Lift Type	52.9"	69.8"	1 3/8"-6 spline	1 3/8"-6 spline

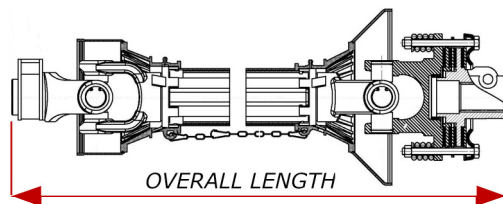

Rotary Cutter (w/ Slip Clutch)

Part #	Series	Used On	Collapsed	Extended	Tractor Yoke	Implement Yoke
89797	4	5' & 6' Lift Type	43"	58.54"	1 3/8"-6 spline	1 3/8"-6 spline (FD1) 2 disc (180mm)
89366	5	6'HD, 8' & 10' Lift Type	45.9"	58.9"	1 3/8"-6 spline	1 3/8"-6 spline (FD2) 2 disc (200mm)
81588	6	6'HD, 8' & 10' Lift Type	45.9"	58.9"	1 3/8"-6 spline	1 3/4"-20 spline 4 disc (180mm)
90647	6	7' HD Lift Type	54.2"	70.74"	1 3/8"-6 spline	1 3/8"-6 spline (FD2) 2 disc(200mm)
105045	6	7' HD Lift Type	54.2"	70.74"	1 3/8"-6 spline	1 3/4"-20 spline (FD2) 2 disc(200mm)
90649	6	15' Flex Wing Shaft	61"	80.74"	1-3/4"-20 spline (I.B.)	1 3/4"-20 spline (FD2) 2 disc (200mm) (I.B.)



BE SURE TO USE PROPER LENGTH PTO!!!

It is not implied in our literature that when a certain size is listed that the length is correct. Some manufacturers use different lengths; that length should be used. The applications recommended are to be considered only as a guide line.

Always allow 1/3 of shaft tube to be in at all times.

ALWAYS KEEP SHIELDING IN WORKING ORDER AND IN PLACE



Agmate Economy Drivelines



Complete PTO Assemblies w/ Shielding

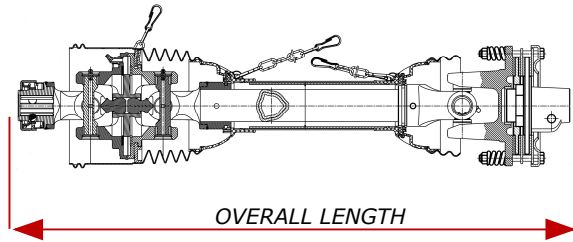

Rotary Cutter (Constant Velocity)

Part #	Series	Type	Collapsed	Extended	Tractor Yoke	Implement Yoke
90650	6	8' & 10' Pull Type	73"	100.8"	1-3/8"-6 Spline	1 3/8"-6 spline (FD2) 2 disc slip clutch (200mm)

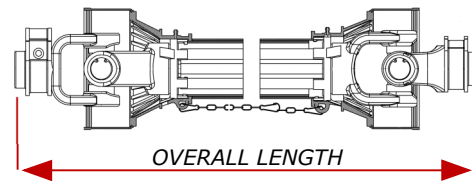

Fertilizer Spreader

Part #	Series	Type	Collapsed	Extended	Tractor Yoke	Implement Yoke
89795	1	Fertilizer Spreader	27"	33"	1 3/8"-6 spline	1 3/8"-6 spline

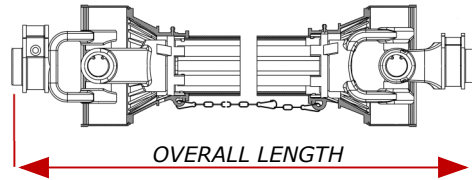

Finishing Mower

Part #	Series	Type	Collapsed	Extended	Tractor Yoke	Implement Yoke
89798	4	Finishing Mower	40.39"	51.9"	1 3/8"-6 spline	1 3/8"-6 spline

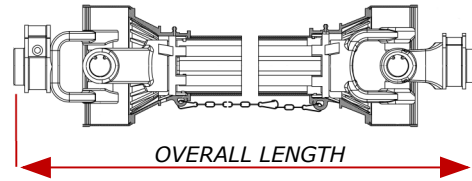

Power Generator

Part #	Series	Type	Collapsed	Extended	Tractor Yoke	Implement Yoke
89799	4	Generator up to 35HP	53"	70"	1 3/8"-6 spline	1 3/8"-6 spline
102974	6	Generator up to 65HP	53"	70"	1 3/8"-6 spline	1 3/8"-6 spline



BE SURE TO USE PROPER LENGTH PTO!!!

It is not implied in our literature that when a certain size is listed that the length is correct. Some manufacturers use different lengths; that length should be used. The applications recommended are to be considered only as a guide line.

Always allow 1/3 of shaft tube to be in at all times.

ALWAYS KEEP SHIELDING IN WORKING ORDER AND IN PLACE



Agmate Economy Drivelines



Complete PTO Assemblies w/ Shielding

Post Hole Digger

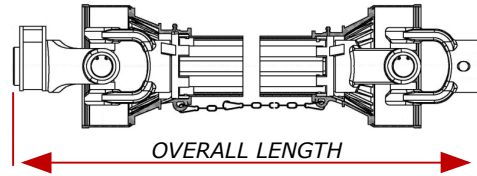

Part #	Series	Type	Collapsed	Extended	Tractor Yoke	Implement Yoke
102265	1	Light Duty PHD	51"	68.9"	1 3/8"-6 spline	1 1/4" rd w/ 3/8" shear pin
84091	2	Medium Duty PHD	51"	68.9"	1 3/8"-6 spline	1 1/4" rd w/ 3/8" shear pin
89806	4	Heavy Duty PHD	51"	68.9"	1 3/8"-6 spline	1 1/4" rd w/ 3/8" shear pin

Sprayer Pump

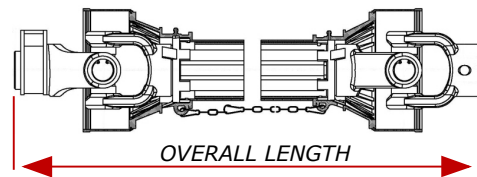

Part #	Series	Type	Collapsed	Extended	Tractor Yoke	Implement Yoke
84348	1	Sprayer Pump	27.75"	37.23"	1 3/8"-6 spline	15/16" rd w/ keyway/ s.s.
89798	4	Sprayer Pump	40.39"	51.9"	1 3/8"-6 spline	1 3/8"-6 spline

Rotary Tiller

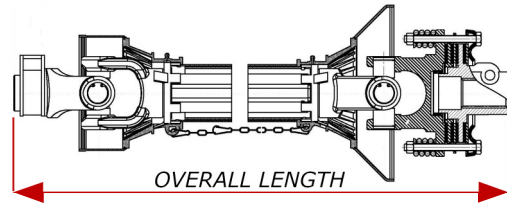

Part #	Series	Collapsed	Extended	Tractor Yoke	Implement Yoke
89364	4	34"	44.2"	1 3/8"-6 spline	1 3/8"-6 spline (FD0) 2 disc slip clutch (160mm)
89807	5	37.72"	46.65"	1 3/8"-6 spline	1 3/8"-6 spline (FD2) 2 disc slip clutch (200mm)

Pond Aerator

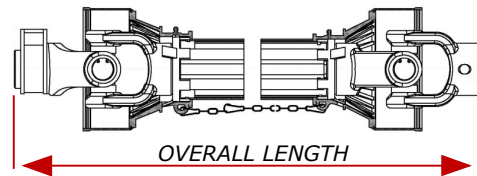

Part #	Series	Collapsed	Extended	Tractor Yoke	Implement Yoke
68383	6	47.9"	73.98"	1 3/8"-6 spline	1 1/2" smooth w/ 3/8" key way & 3/8" 16 unc set screw



BE SURE TO USE PROPER LENGTH PTO!!!

It is not implied in our literature that when a certain size is listed that the length is correct. Some manufacturers use different lengths; that length should be used. The applications recommended are to be considered only as a guide line.

Always allow 1/3 of shaft tube to be in at all times.

ALWAYS KEEP SHIELDING IN WORKING ORDER AND IN PLACE



Agmate Economy Drivelines



PTO Parts

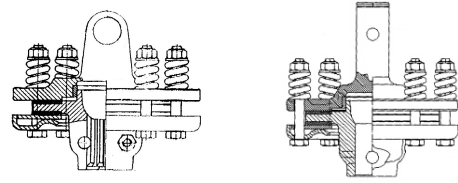

Slip Clutch

Part #	Series	To Fit	Description
102578	FD0	Series# 4	2 Disc Slip Clutch (1-3/8" 6 spline) 160mm
TBD	FD1	Series# 4	2 Disc Slip Clutch (1-3/8" 6 spline) 180mm
102574	FD1	Series# 5	2 Disc Slip Clutch (1-3/8" 6 spline) 180mm
102575	FD2	Series# 5	2 Disc Slip Clutch (1-3/8" 6 spline) 200mm

Slip Clutch Attachments

Part #	Series	Type	O.A Length	Tractor End	Implement End
90653	FD1	Smooth	7.23"	1 3/8" smooth bore female	1 3/8" smooth bore male
102247	FD1	Spline	7.23"	1 3/8"-6 spline female	1 3/8"-6 spline male

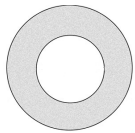

Part #	Description	Pad O.D.	Pad I.D.	Pad Thickness
102576	Friction Disc for FD0 (160mm) Slip Clutch	120mm	68.54mm	3mm
102577	Friction Disc for FD1 (180mm) Slip Clutch	140mm	85mm	3.6mm
102579	Friction Disc for FD2 (200mm) Slip Clutch	160mm	98mm	3.6mm

Over-Running Attachments

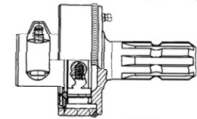

Part #	Series	O.A Length	Tractor End	Implement End
90654	RLS1	6.85"	1 3/8" -6 spline male	1 3/8"-6 spline female

Cross Shafts (Gearbox Connectors)

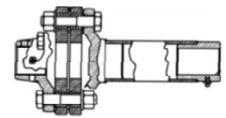

Part #	Type	To Fit:	O.A. Length	Tractor End
77754	Single Pad	8' Cutter	12.5"	1 3/8"-6 spline female both ends
77755	Double Pad	10' Cutter	18.5"	1 3/8"-6 spline female both ends

Cross Shaft Pads- "Flex Pads"

Part #	Diameter	Thickness	Center Hole	Bolt Hole	Bolt Spacing
77879	6"	.39"	2.2"	.68"	4.5"
72193	6-3/8"	.74"	2.2"	.87"	4.5"

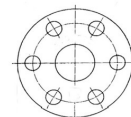

Cross Shaft "Spider" Hub

Part #	Type
84068	1- 3/8 6 Spline Hub to fit Item# 77754 and 77755

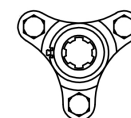

Agmate Economy Drivelines



PTO Parts

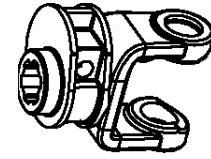

Spline Bore Yokes

Part #	Description	Style
62564	Series 1 - 1 3/8"-6 spline	Push Pin
102975	Series 4 - 1 3/8" -6 spline	Push Pin
102976	Series 5 - 1 3/8" -6 spline	Push Pin
102702	Series 6 - 1 3/8" -6 spline	Push Pin
62578	Quick Disconnect Push Pin Repair Kit	Universal

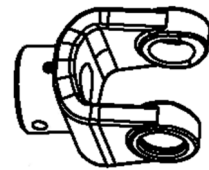

Smooth Bore Yokes

Part #	Description
62565	Series 1 - 1 1/4" w/ 3/8" shear pin
62576	Series 3 - 1 1/4" w/ 3/8" shear pin
102986	Series 4 - 1 1/4" w/ 3/8" shear pin
102985	Series 4 - 1 3/8" w/ 1/2" shear pin
84069	Series 6 - 1 3/8" w/ 1/2" shear pin
90556	Series 6- 1-3/4" rd w/ 3/8" keyway + setscrew
70127	Set Screw & Nut for 1-1/4" PHD yokes (6mm x 1.0mm)

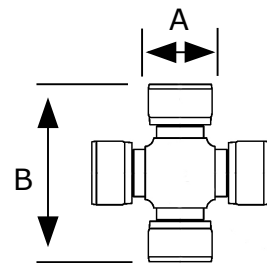

Cross Kits

Part #	Description	Cap Diameter (A)	Cross Height (B)
62561	Series 1	22mm	54mm
102261	Series 2	23.8mm	61.3mm
102253	Series 3	27mm	70mm
102977	Series 4	27mm	74.6mm
102978	Series 5	30.2mm	80mm
102580	Series 6	30.2mm	92mm
102262	Series 6 (CV)	27mm x 30.2mm	100mm x 92mm
62579	Grease Zerk- 45 Degree 8mm- To Fit all Cross Kits		

Agmate Economy Drivelines



PTO Parts

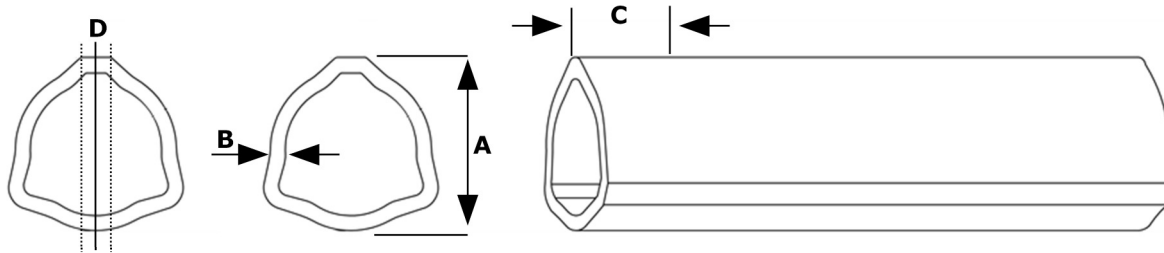

Tubing

(All Tubes are 59" Long. Customer, cut to length as needed)

Part #	Description	Tube Height "A"	Thickness "B"	Hole Location "C"	Hole Size "D"
102581	#1 inner tube	26.6mm	3.5mm	16mm	8mm
102582	#1 outer tube	32.4mm	2.5mm	16mm	8mm
102583	#4 inner tube	36.1mm	4.4mm	16mm	8mm
102584	#4 outer tube	43.4mm	3.3mm	16mm	8mm
102585	#5 inner tube	44.7mm	4mm	16mm	10mm
102586	#5 outer tube	51.3mm	2.9mm	16mm	10mm
102587	#6 inner tube	44.7mm	4mm	16mm	10mm
102588	#6 outer tube	53.6mm	3.8mm	16mm	10mm

Roll Pins



Part #	Description	Dimensions
36572	#1 inner tube Roll Pin	8mm x 45mm
33045	#1 outer tube Roll Pin	8mm x 50mm
33046	#4 inner tube Roll Pin	8mm x 55mm
36573	#4 outer tube Roll Pin	8mm x 60mm
36574	#5 inner tube Roll Pin	10mm x 65mm
36559	#5 outer tube Roll Pin	100mm x 75mm
36575	#6 inner tube Roll Pin	10mm x 70mm
32486	#6 outer tube Roll Pin	10mm x 80mm

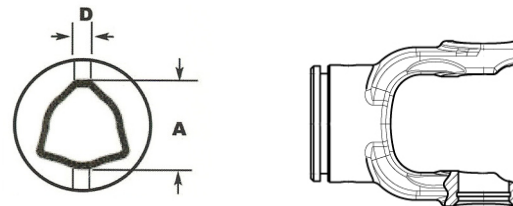

Tube Yokes

Part #	Description	Tube Height "A"	Hole Size "D"
102589	#1 inner tube yoke	26.6mm	8mm
102593	#1 outer tube yoke	32.4mm	8mm
102590	#4 inner tube yoke	36.1mm	8mm
102594	#4 outer tube yoke	43.4mm	8mm
102591	#5 inner tube yoke	44.7mm	10mm
102595	#5 outer tube yoke	51.3mm	10mm
102592	#6 inner tube yoke	44.7mm	10mm
102596	#6 outer tube yoke	53.6mm	10mm